

Fully Framed Rapid Response Duffel Locker – KD Assembly Instructions – 4 TIER



Fasteners & Tools Needed

The following items are in the hardware kit shipped with the locker:

8615–Number plate



8671–Aluminum Rivet



8621- Steel rivet

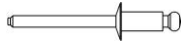

8709-Screw



..

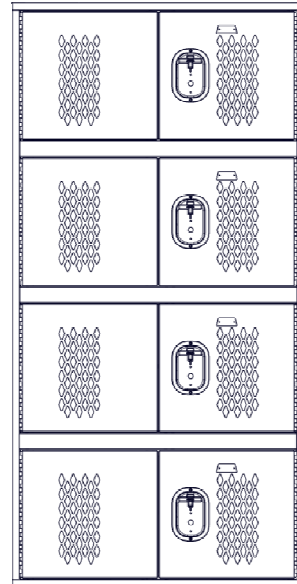

STEP 1- Check Parts

Unpack the component pieces for the basic locker. You should have two sides, a back, a top, and bottom, Horizontal Channel/s, Shelf/Shelves, left hand and right hand doors.

You will need these tools to assemble the Patriot Gear locker.

Rivet gun.

Drill with #3 Philips bit



Flat blade and Phillips head screwdrivers.

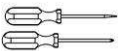

Stepladder

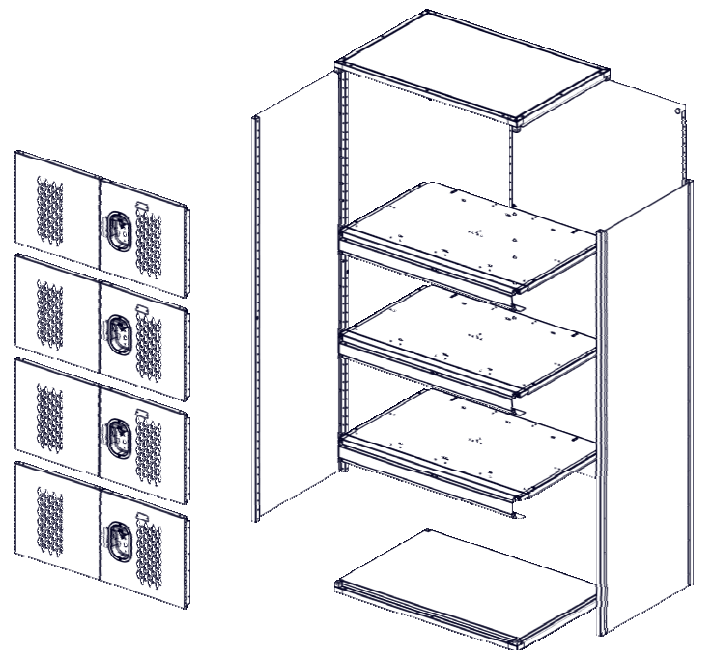

Note- Assemble locker upside down to allow screw insertion into underside of locker bottom. Images shown may differ from your locker, as there are different configuration options. Some parts show with transparency in these instructions to add clarity to assembly.

STEP 2 – Assemble the locker body

2A- Lay locker top on flat surface on the ground. Insert the two sides onto the cast corner pieces of the top assembly.

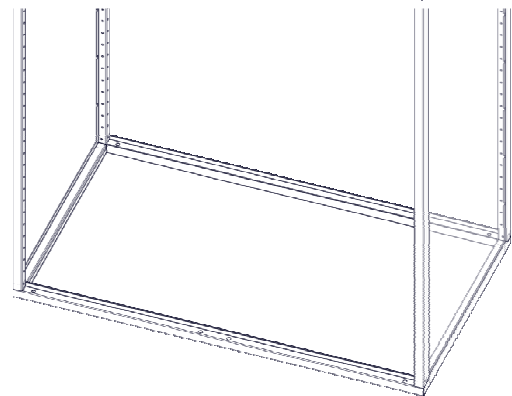
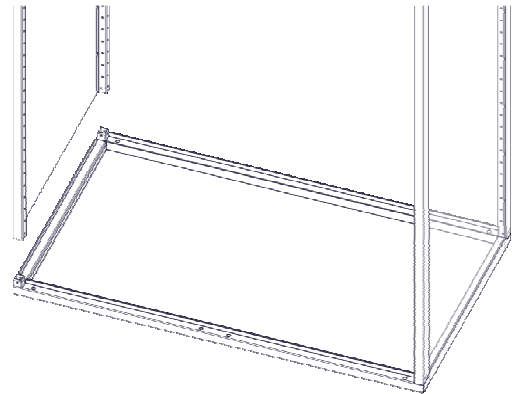
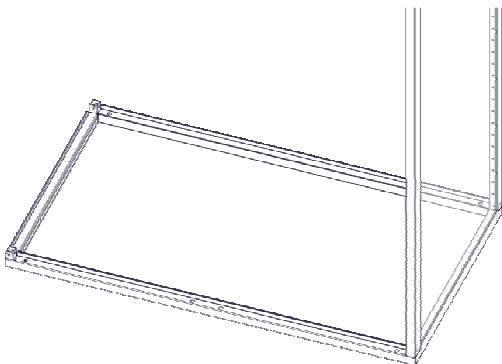
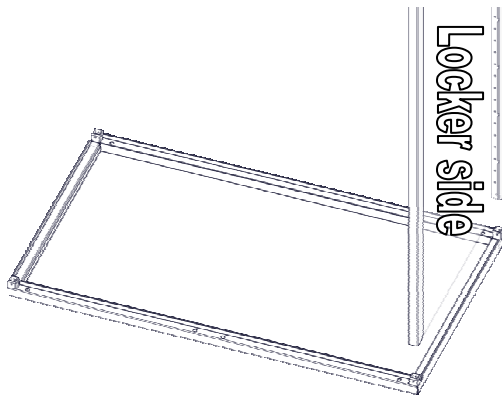
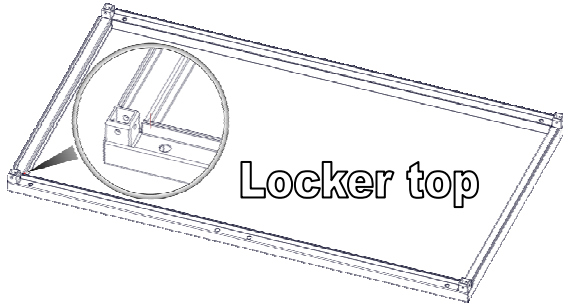

2B-1 Insert locker back into slot of the top.

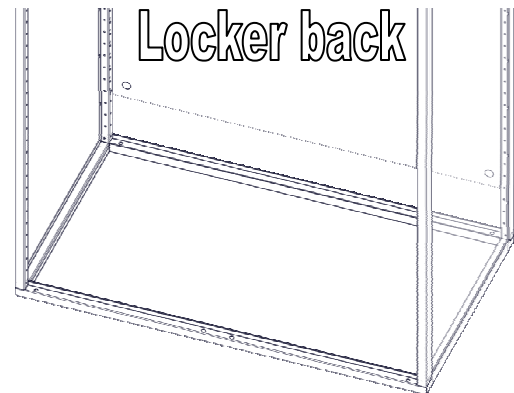

Fully Framed Rapid Response Duffel Locker – KD

Assembly Instructions – 4 TIER

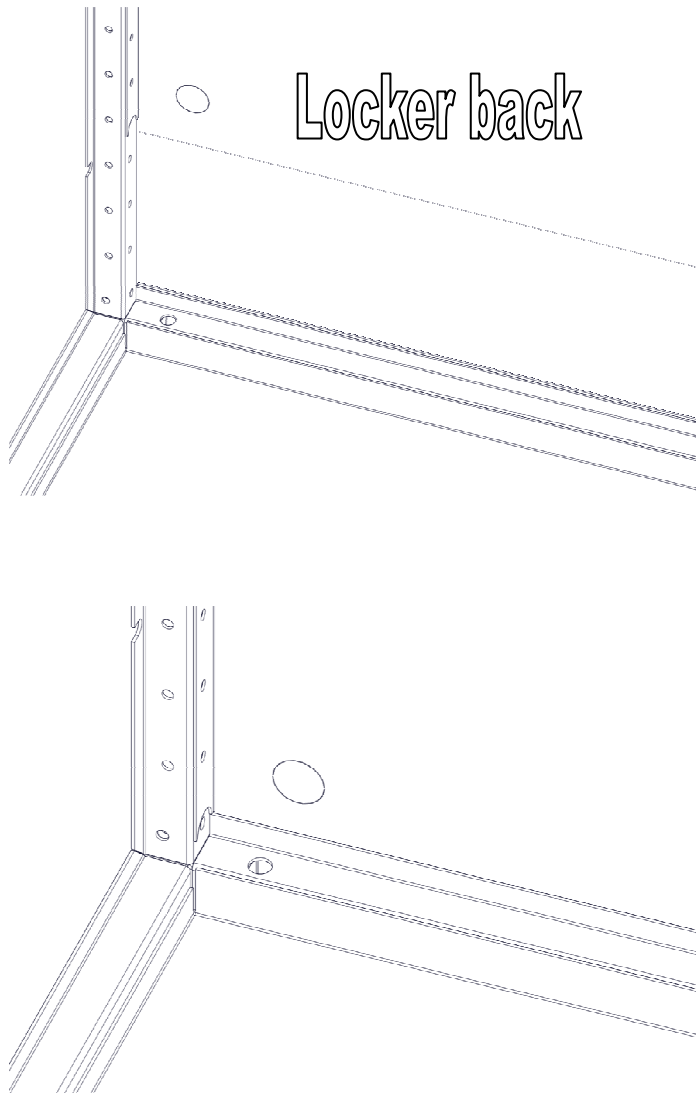

2B-2 With the back inserted install one 8709 screw on each side of the back about half way up. Note holes are to align to make sure back is in proper position.

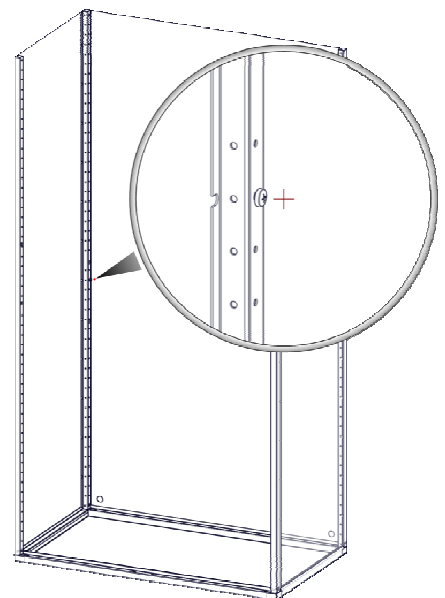
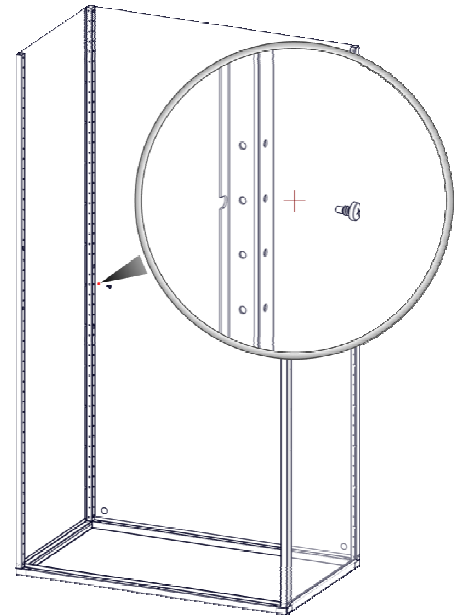

Fully Framed Rapid Response Duffel Locker – KD

Assembly Instructions – 4 TIER



2C-1 Insert cast corner pieces of locker bottom into the side channels.

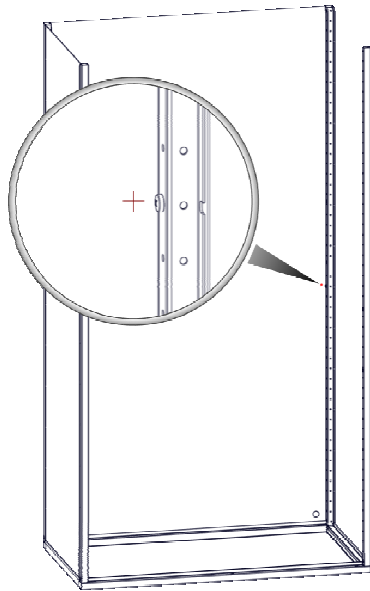
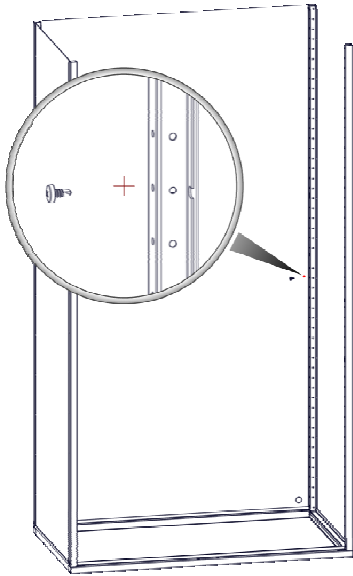

Locker bottom

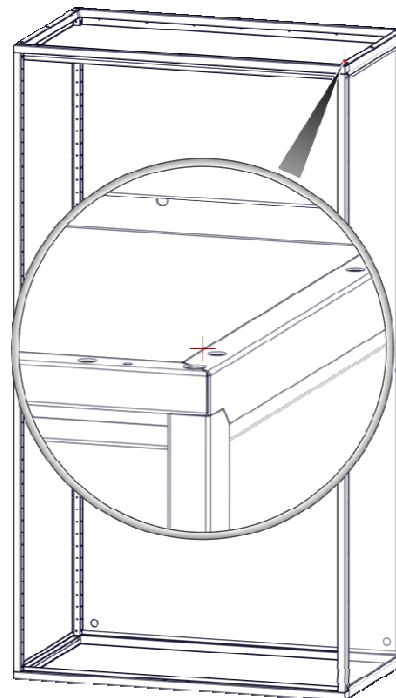
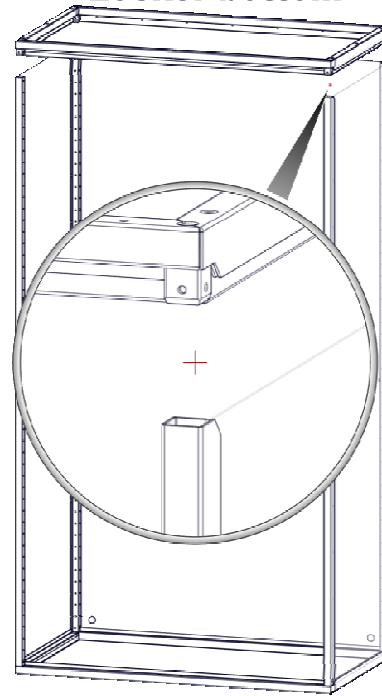

Fully Framed Rapid Response Duffel Locker – KD Assembly Instructions – 4 TIER



2C-2 Install one screw into each corner of the locker bottom as shown.

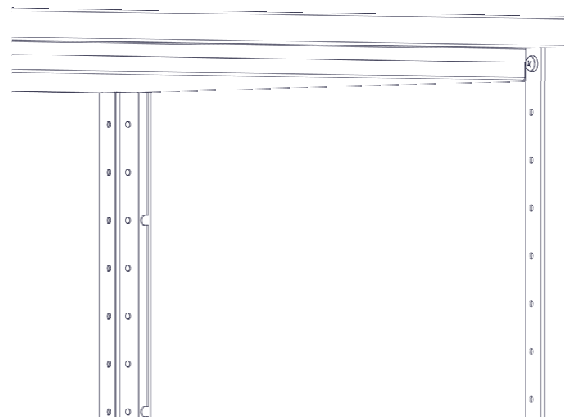
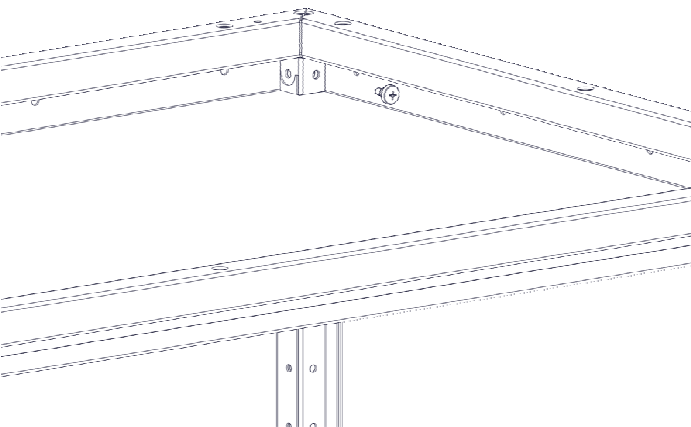
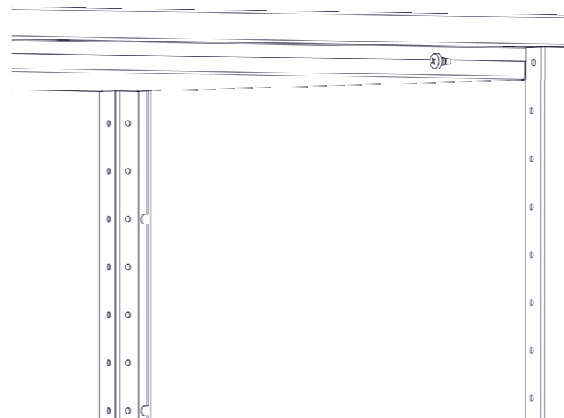
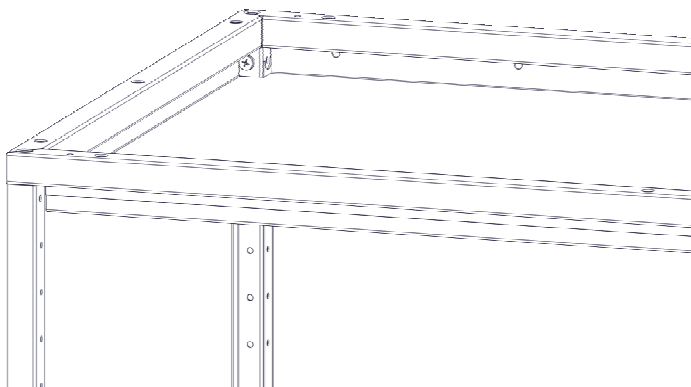
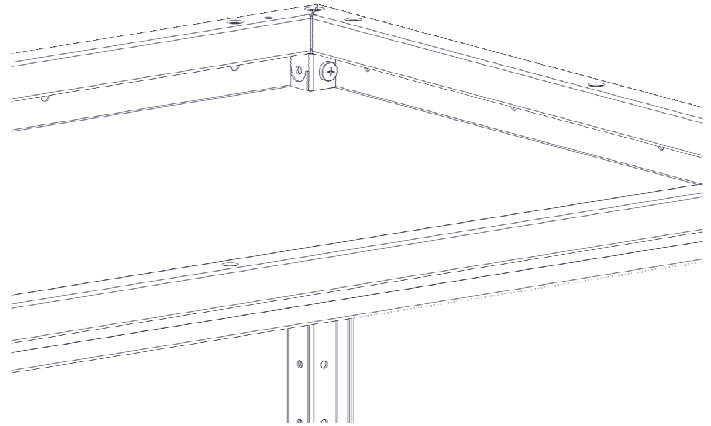
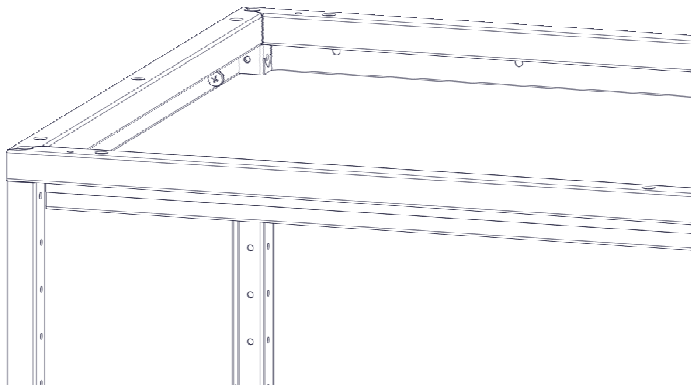

Fully Framed Rapid Response Duffel Locker – KD Assembly Instructions – 4 TIER

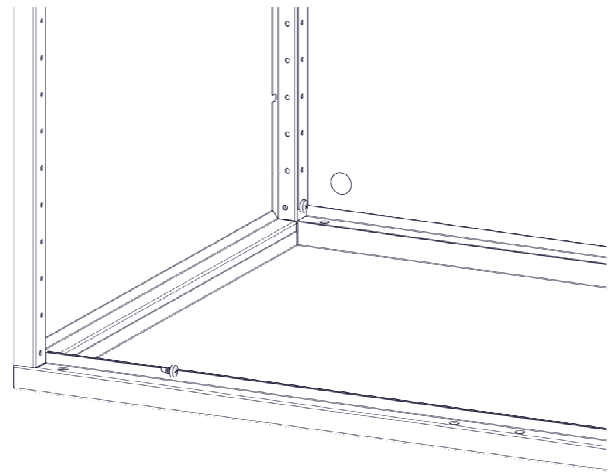
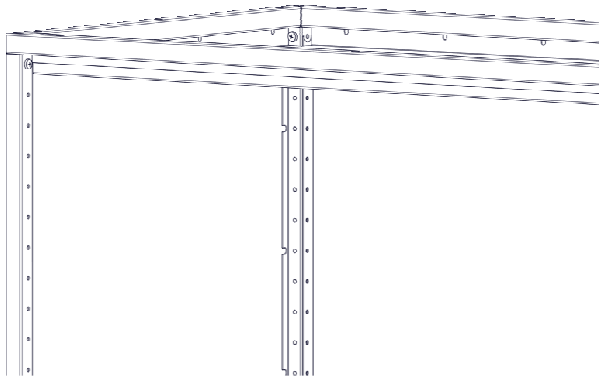
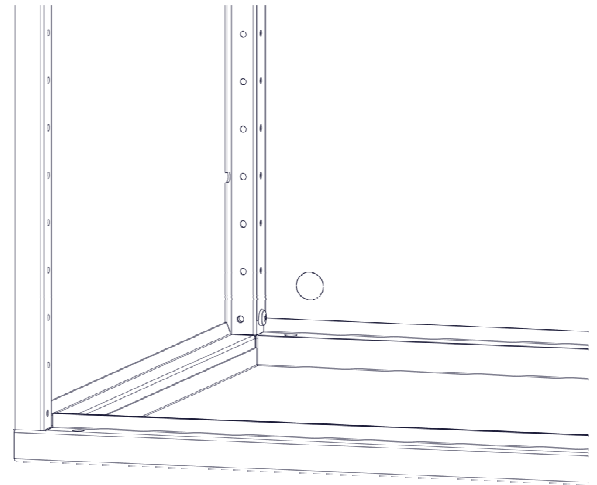
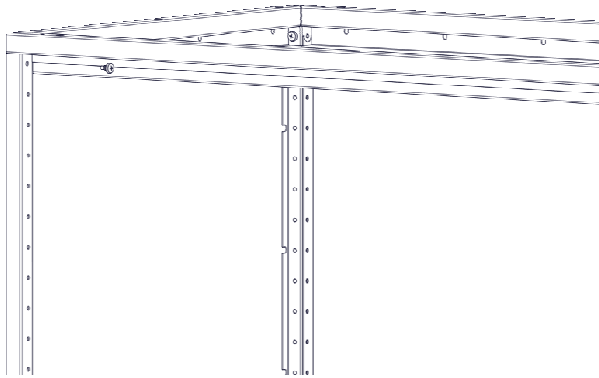

2D- Next install one screw into the locker top in each corner as shown.

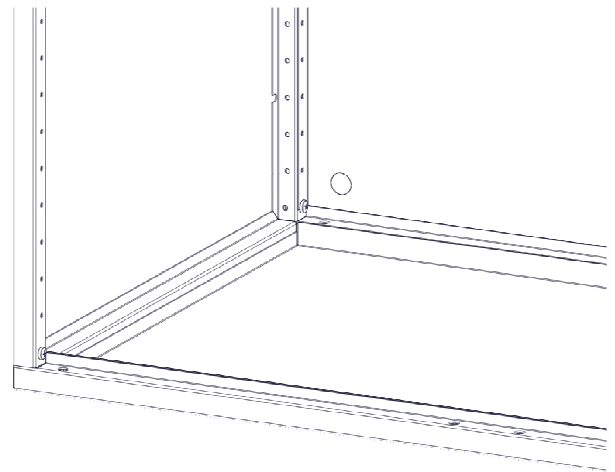
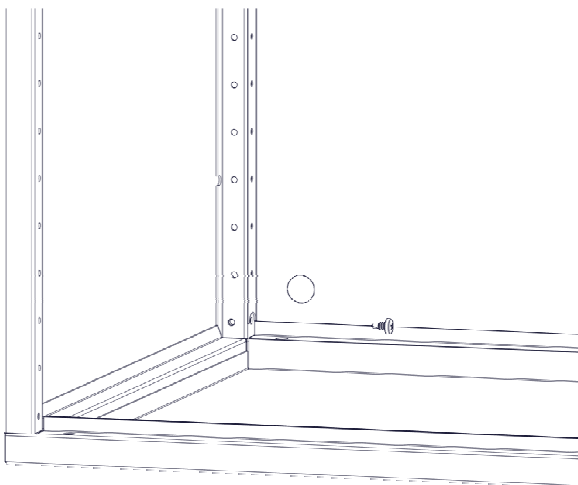

Fully Framed Rapid Response Duffel Locker – KD Assembly Instructions – 4 TIER

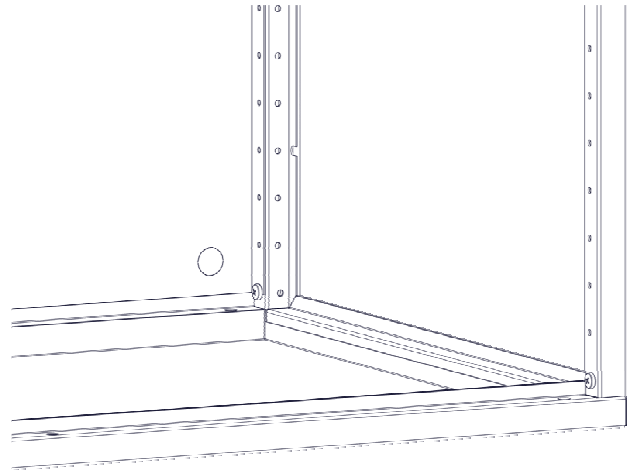
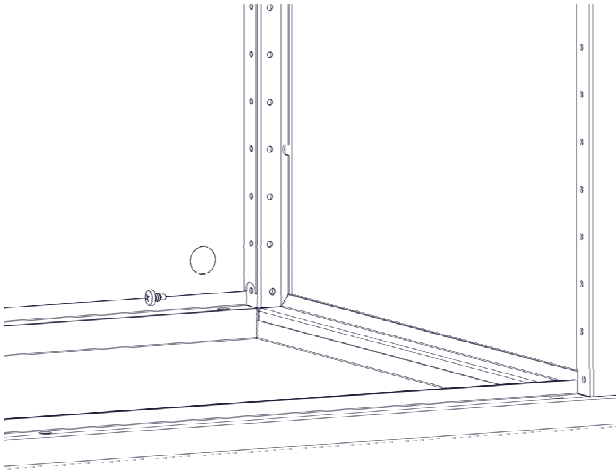

2E- Now rotate locker body so the bottom is on the ground.

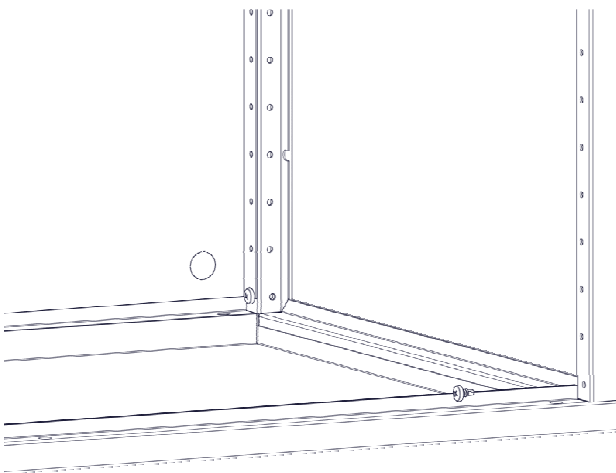
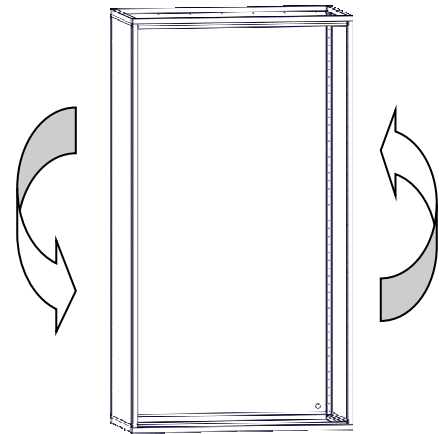
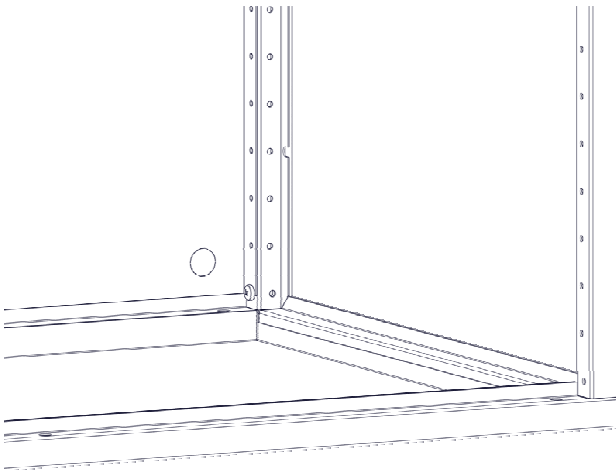

Fully Framed Rapid Response Duffel Locker – KD Assembly Instructions – 4 TIER

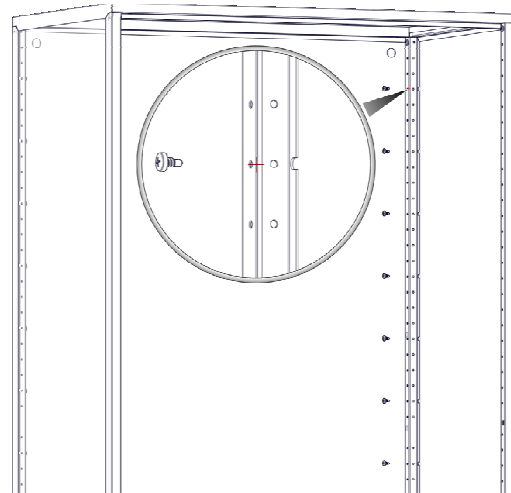
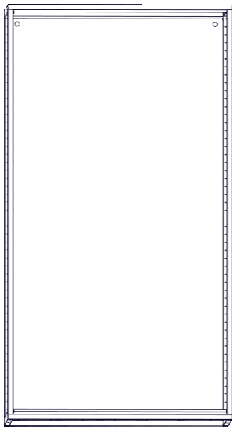
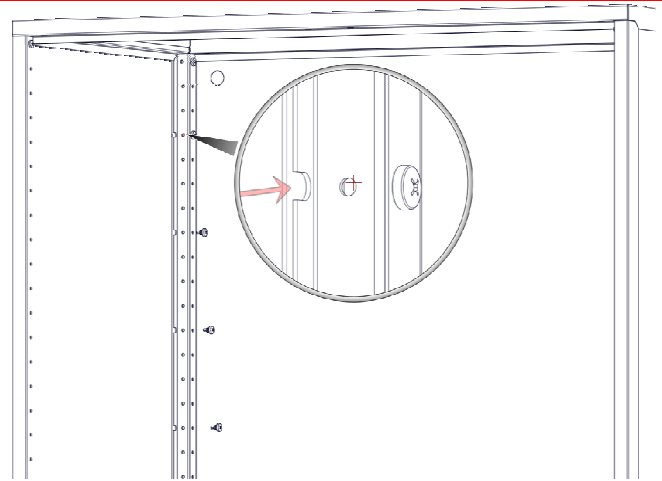
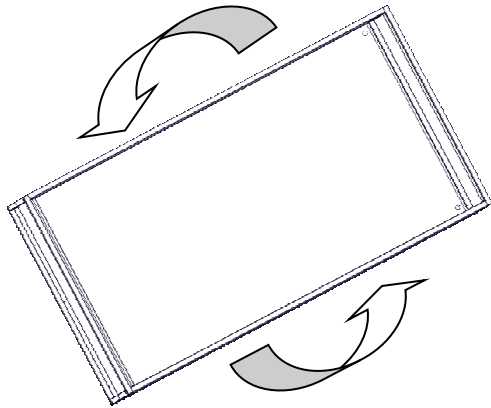

2F-Install screws to locker back at U cut locations (6-inch intervals) on each side.

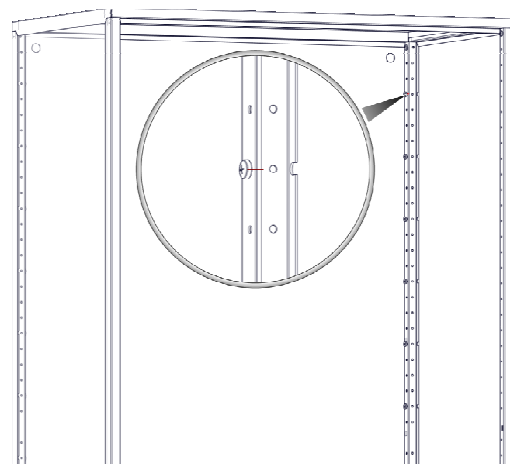
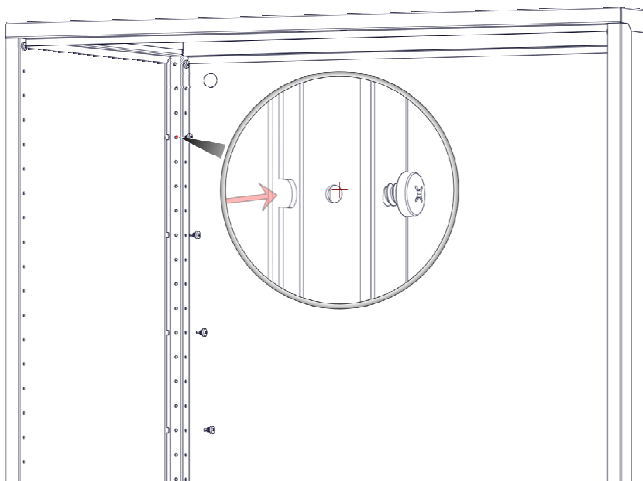

Fully Framed Rapid Response Duffel Locker – KD Assembly Instructions – 4 TIER



2G-Install doors using 8621 rivets at each hole location on hinge.

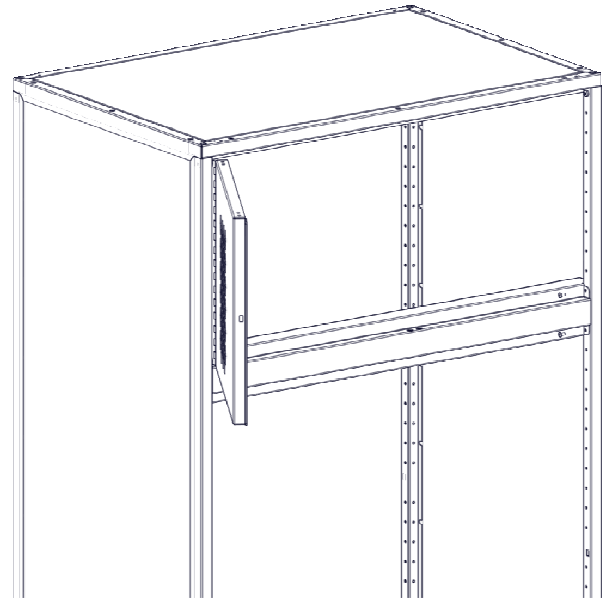
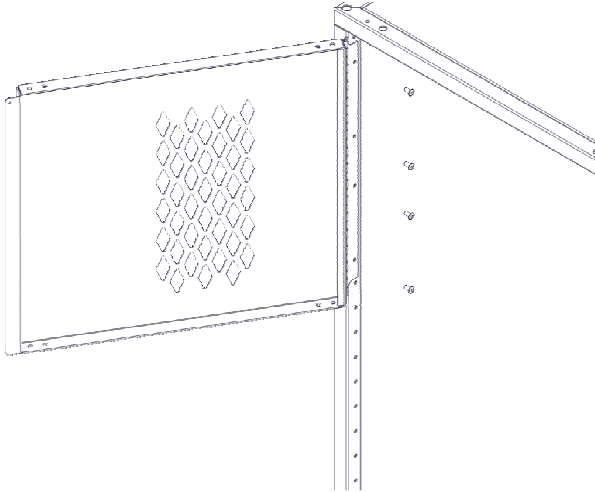

2H-Install Horizontal Channel using directly below door using 8621 rivets at each hole location on each side.

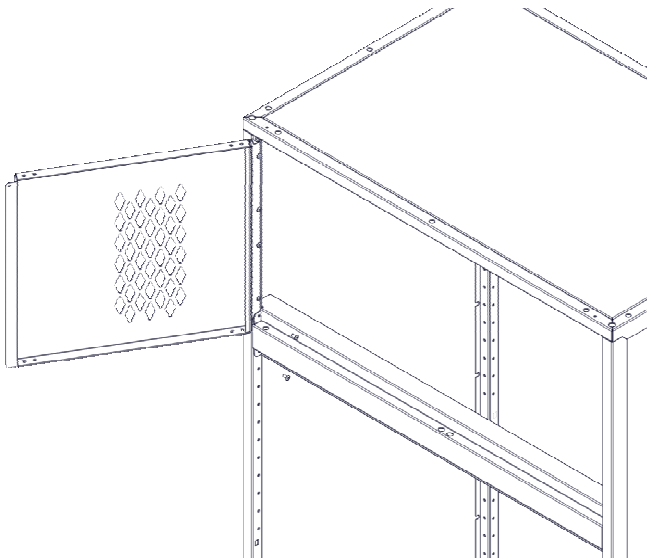

2I-Install door using 8621 rivets at each hole location on hinge.

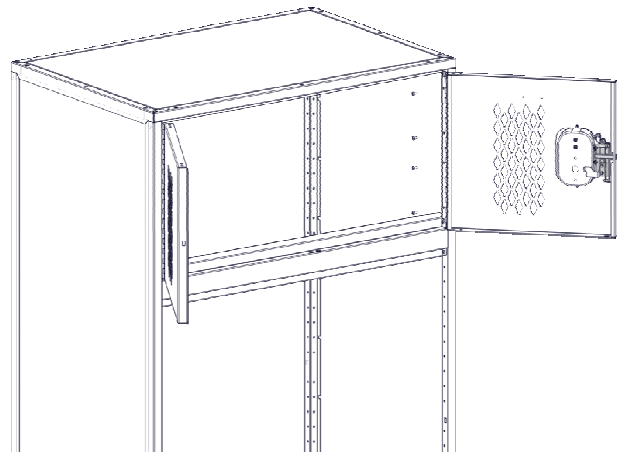

Fully Framed Rapid Response Duffel Locker – KD

Assembly Instructions – 4 TIER



2J-Install shelf support rails and attach using screws in each vertical corner post.

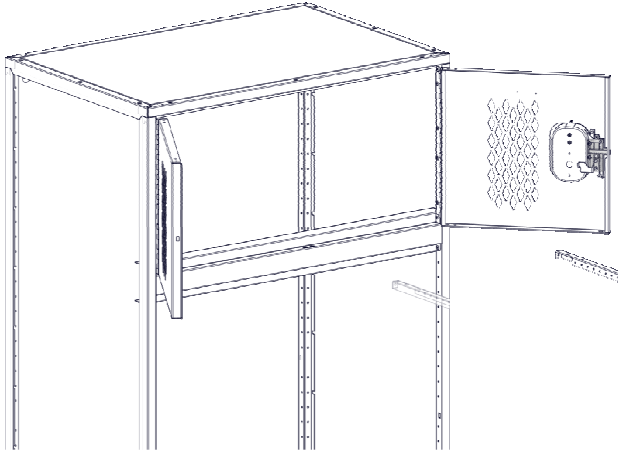

2K-Install shelf onto supports and riveting in four places.

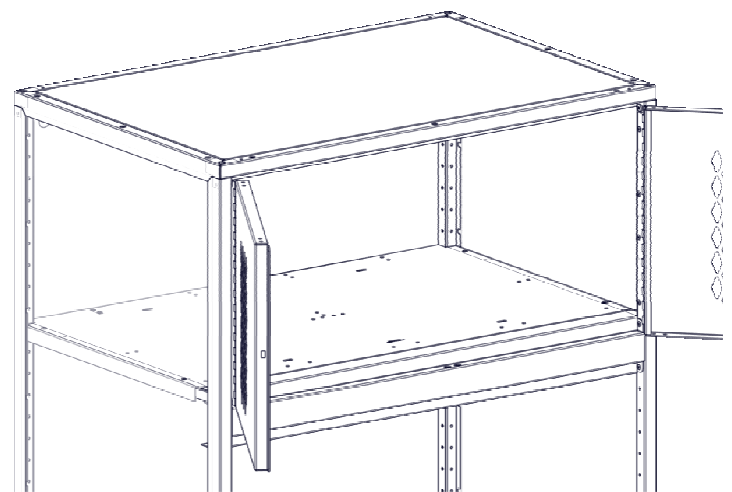
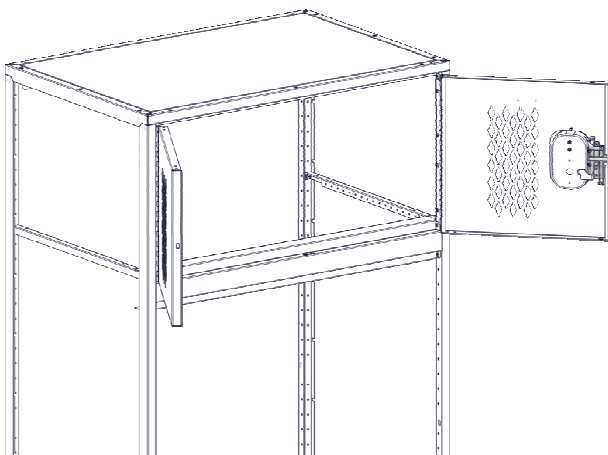
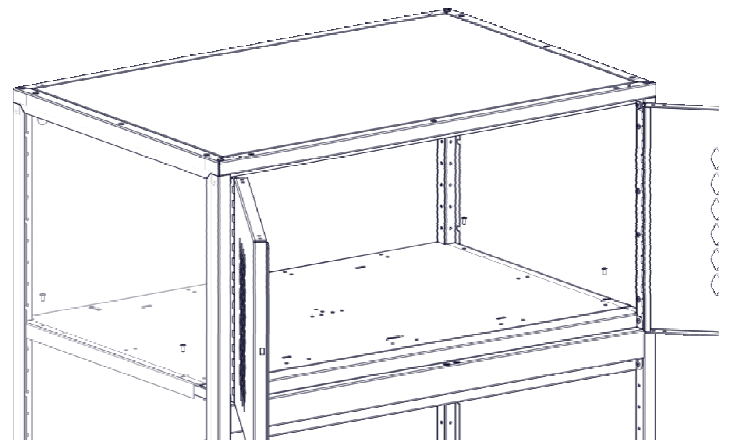
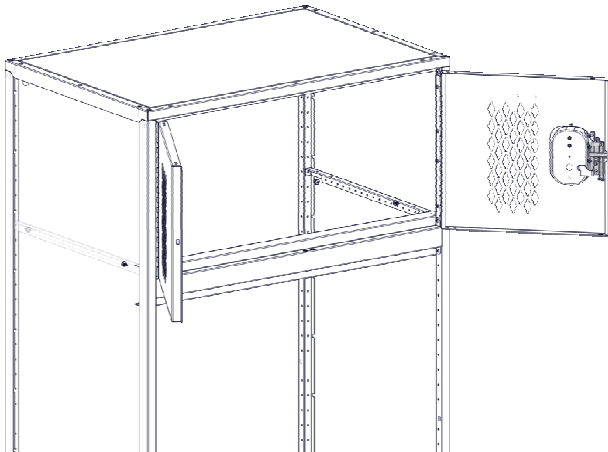
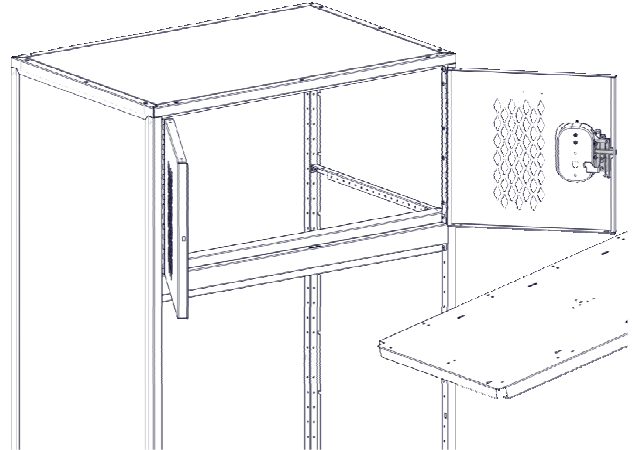

Fully Framed Rapid Response Duffel Locker – KD

Assembly Instructions – 4 TIER



Repeat steps 2G-2K until all doors, horizontal channels, and shelves are installed.

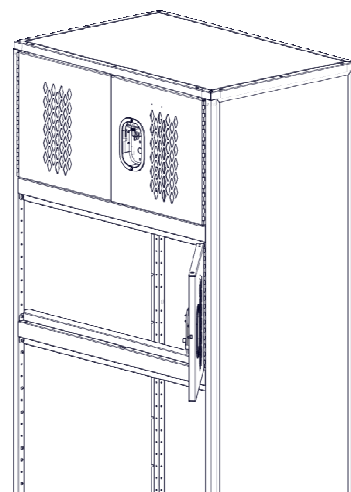
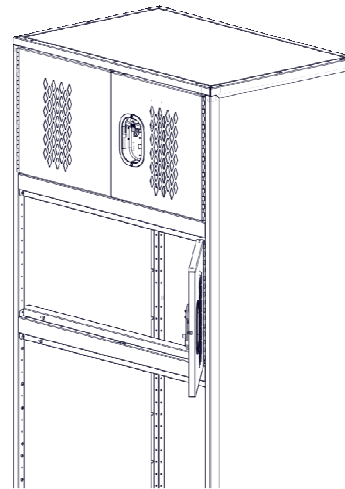
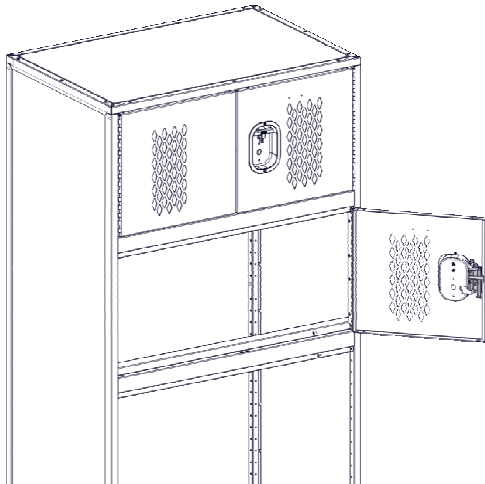
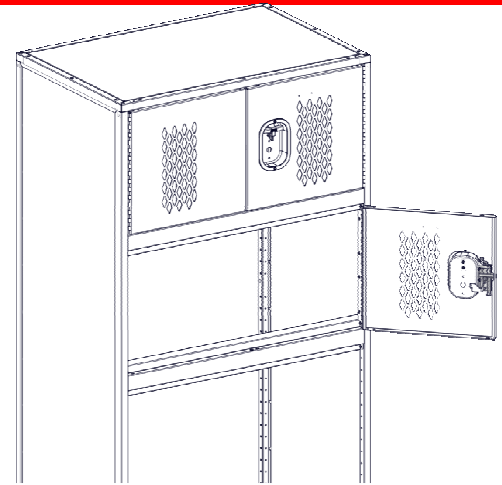
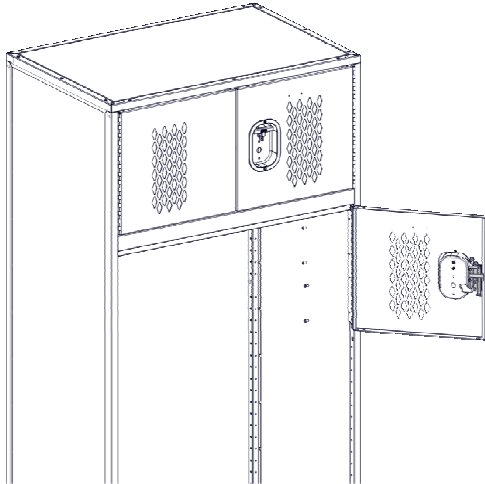

Fully Framed Rapid Response Duffel Locker – KD Assembly Instructions – 4 TIER

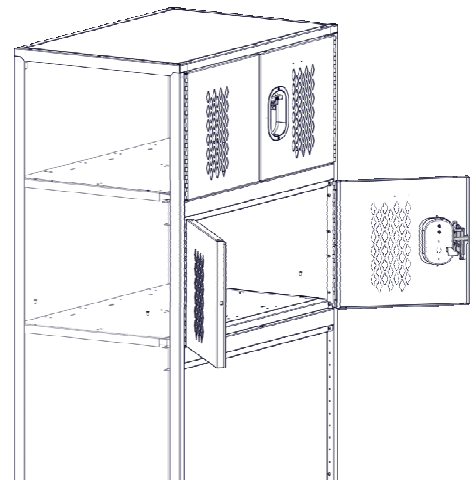
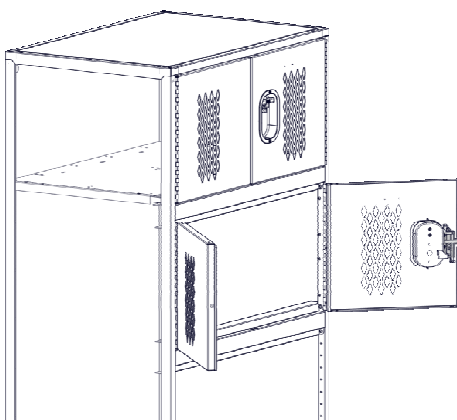
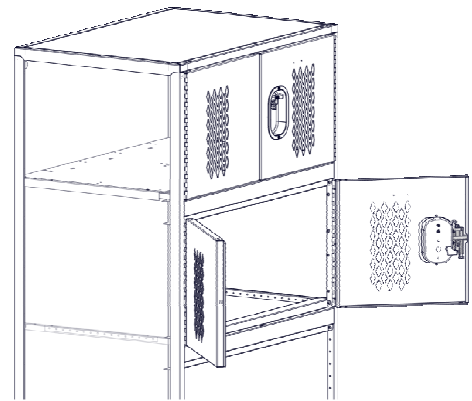
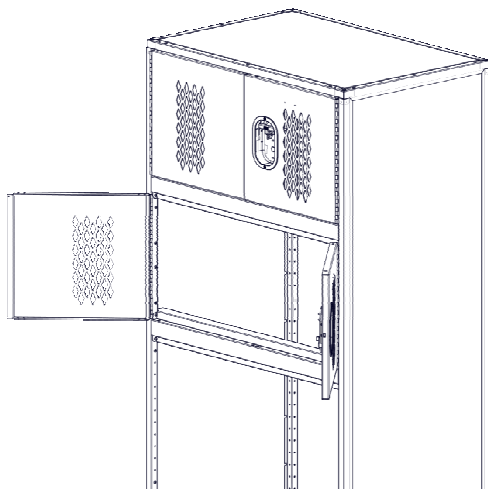
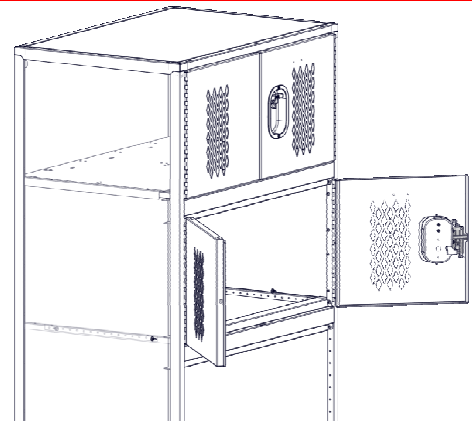
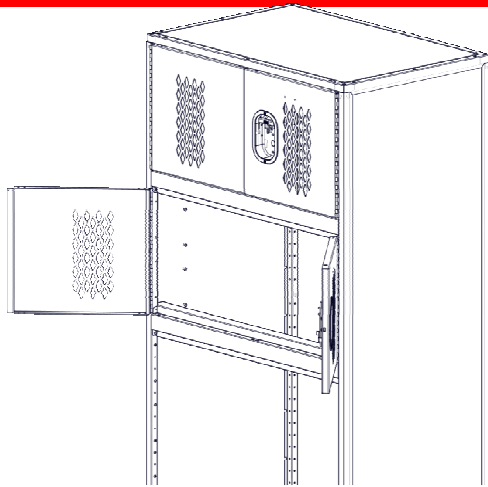

Fully Framed Rapid Response Duffel Locker – KD Assembly Instructions – 4 TIER

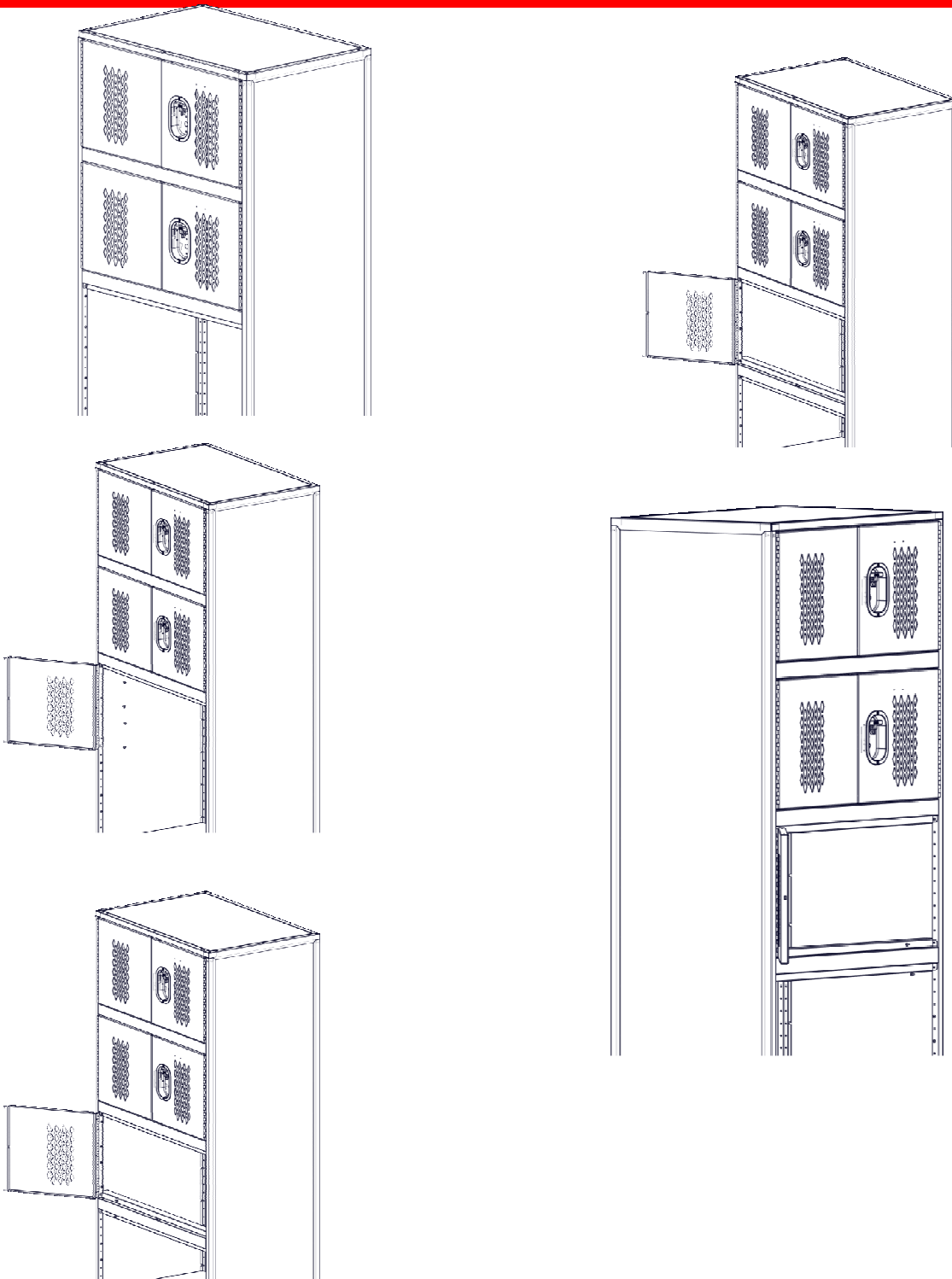

Fully Framed Rapid Response Duffel Locker – KD Assembly Instructions – 4 TIER

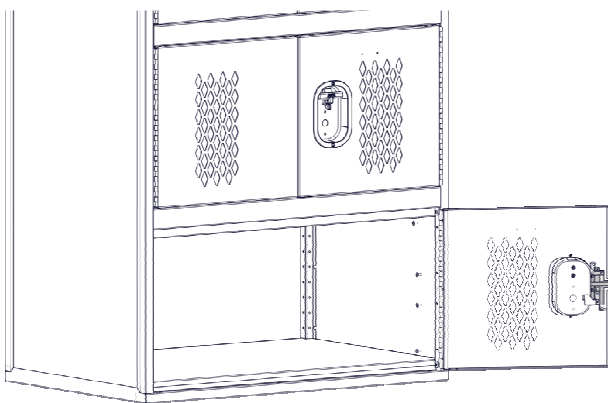
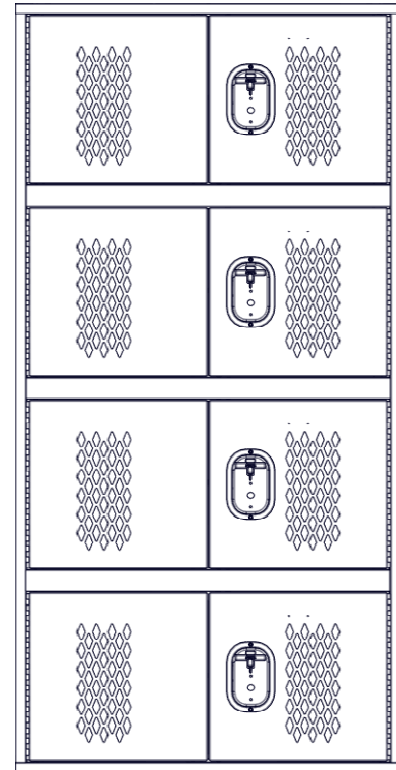
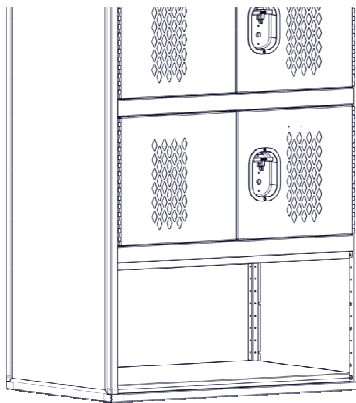
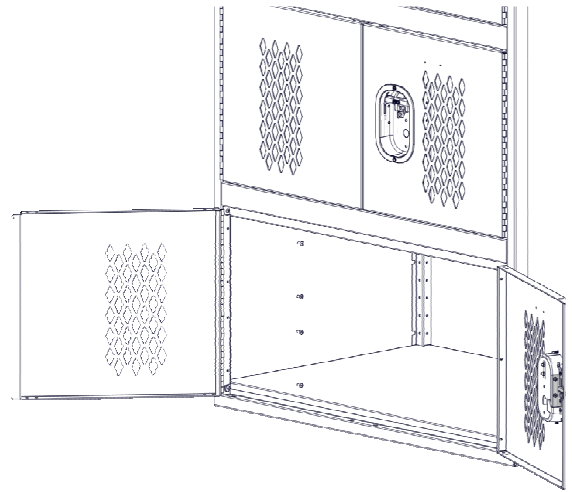
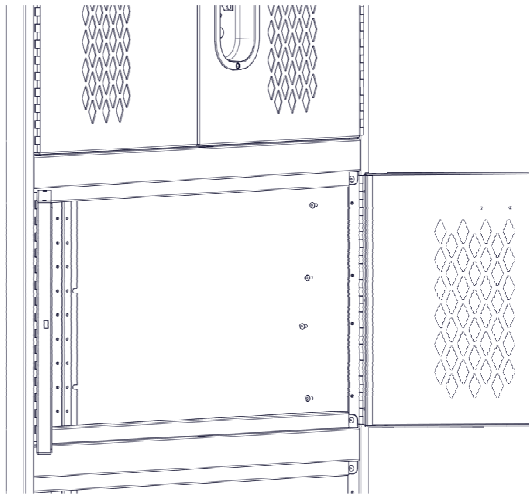

Locker assembly is now complete. Lockers to be floor and wall anchored before use.