

Introduction

Penco Pallet Rack

Penco Pallet Rack is a carefully engineered system designed to provide highly efficient storage of palletized items. Combining design and excellence with the use of high strength steel to achieve a superior strength to weight ratio, Penco Pallet Rack can handle nearly any storage job you can give it.

The basic components of Penco Pallet Rack are Upright Frames and Beams. Each is manufactured to exacting tolerances to provide many years of dependable service at their rated loads.

The following pages detail the wide range of sizes, capacities and accessories that make Penco Rack one of the best values for your storage dollar.



Available in
24 Colors
See Page 120

Welded Upright Frame

Beams

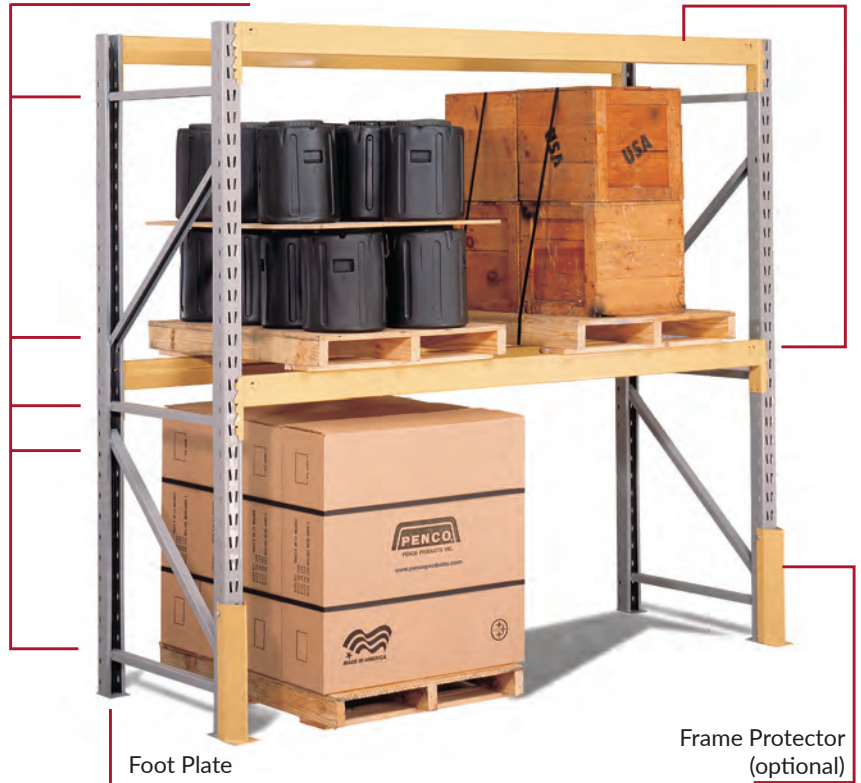

Foot Plate

Frame Protector
(optional)

Design Features

Heavy Duty Beam End Connector

Beam ends are made from extra heavy gauge steel. They feature a three prong connection which assures positive beam to post alignment along the 8-1/2" length of the connector, and uniform load distribution. The greater the load, the tighter the connection. Tabs extend along the face of the beam to provide extra protection to the prongs during transit and installation.

Upright Column

A continuous post roll formed in 5 different shapes and 3 different metal thicknesses to handle a variety of loads. Slanted slots on the column allow for beam placement on 3" vertical centers. Slots on column sides accept the safety beam locking key. The design allows for beams to be placed flush with the top, or as close as 9" from the floor.

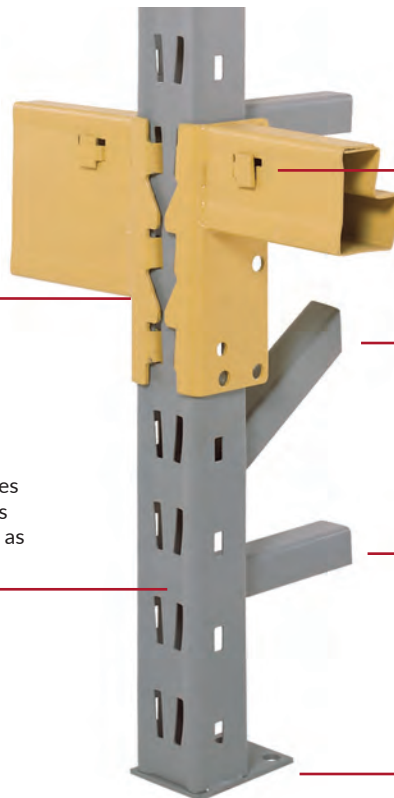

Beam Locking Key for Safety

A unique recessed safety key made from heavy gauge steel engages a slot in the side of the post. It resists an upward force from material handling equipment up to 1000 pounds. It is an integral part of the beam assembly, can be engaged easily without tools, and is clearly visible for checking.

Step Down Design

All beams have a step for the purpose of accepting accessories. Two step sizes are available: 7/8" and 1-5/8" high.

Welded Upright Frame Bracing

Upright frame columns are securely MIG welded together with channel type braces for maximum rigidity.

Foot Plate

A heavy gauge foot plate is securely welded to each post to provide load distribution over 13.7 square inches, and two holes allow for floor anchoring from either side of the frame.

Design Considerations

Determining Pallet Rack Needs

- A. Height:** Measure the vertical dimensions of the pallet, pallet load and beam. Add an extra 4" to 6" clearance between bottom of beam above and top of load on pallet. Top beam should be at least 6" lower than the maximum lifting height of your forklift.
- B. Depth:** Measure the depth of the pallet. Pallet should overhang the frame by 3" front and back. (Example: for a 48" deep pallet use a 42" deep frame).
- C. Width:** Measure the width of the load and pallet, and use the greater of the two. Add 3" to 4" between loads, and between loads and upright frames to determine correct beam length. Select beams with a capacity equal to or greater than the total load of each level. (See "How to Order Beams" on the Pallet Rack Beam page).
- D. Frame Capacity:** Add the total weight of all loads for each bay, excluding the pallets on the floor (a bay is the space between two upright frames).
- E. Frame:** A common frame should be used between each bay.

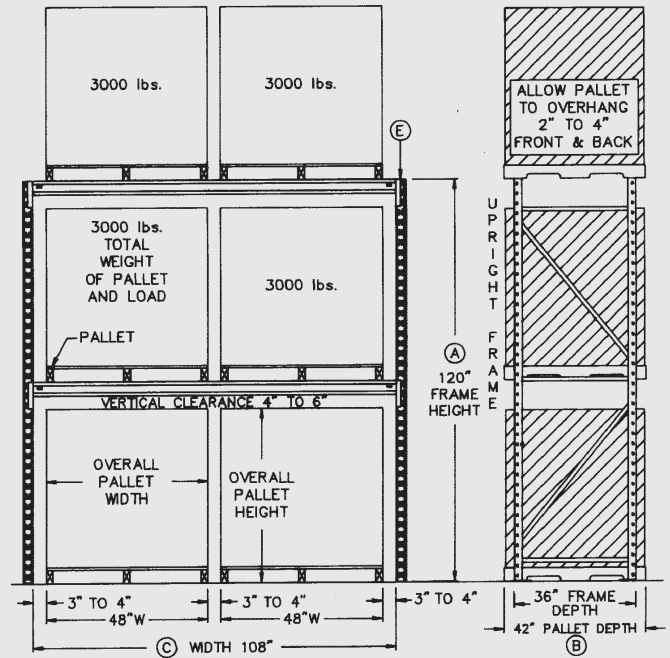

Pallet Rack Plus - An option for severe conditions or high seismic activity

Penco Pallet Rack Plus is engineered for use in areas where high seismic activity or other severe conditions exist. Load capacities are the same as the standard pallet rack shown in this catalog, however the frames and beams are more resistant to horizontal and vertical forces that could damage standard rack and its load. To learn the seismic rating where your pallet rack will be in use, contact your Penco representative.

Plus Beam End Connectors:

The Plus beams have 4 connectors instead of 3 for a stronger connection between

the beam and the upright post to resist conditions with higher lateral forces. The beam is welded 3" down from the top of the connector so loading is evenly distributed across all four connector prongs. The beam locking key is the same as used on standard beams.

Plus Upright Frames with Large Footplates:

Each Plus upright frame has two 5" x 7" x 3/8" thick footplates with four 9/16" diameter anchoring holes. The extra holes provide the installer with more choices for floor anchoring.

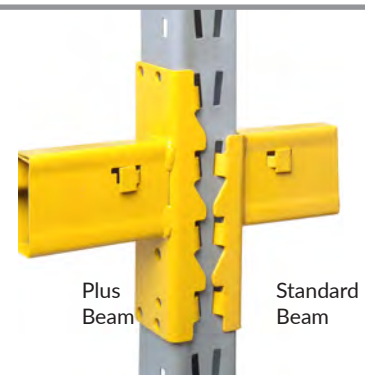
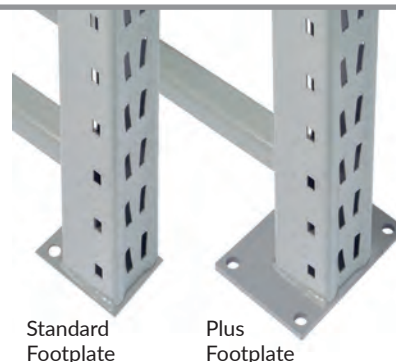
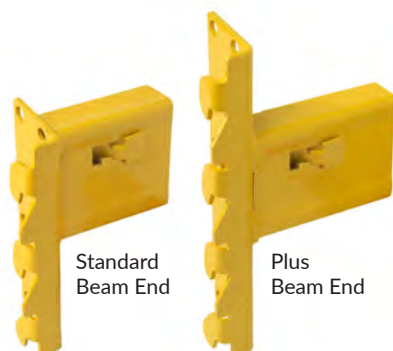

Upright Frames

Penco Pallet Rack Upright Frames are available in five load capacities. A letter code stamped into the face of the post indicates the frame type. Depths of 30", 36", 42", 48", 54" and 60" are standard, but other depths and double-posted and cantilever frames are available. Standard heights range from 48" to 240" in 6" increments, but greater heights can be achieved when splices are used.

Beam heights adjust on 3" vertical centers, and are independent on each side of the frame. Beams of any type can be placed along the full height of the post; there are no dead spots on the post, even across a splice. Various load rated frames can be combined in a row of rack for maximum economy.

Penco Pallet Rack Upright Frames are furnished completely fabricated, welded into rigid units.

Panel Construction:

Four standard types of panel construction are illustrated.

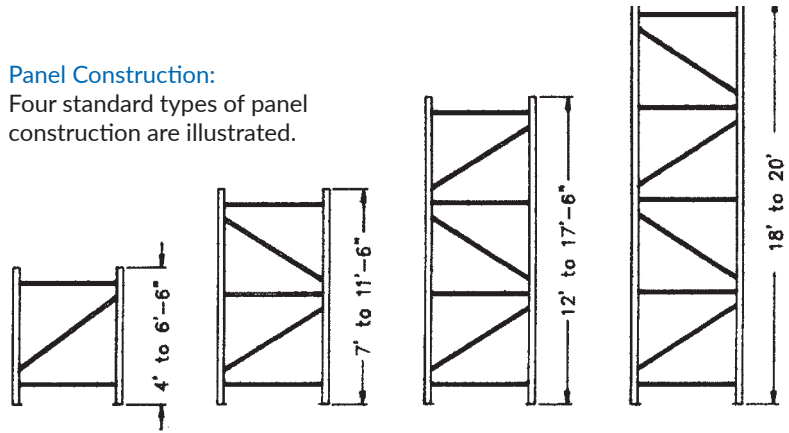

How To Select Upright Frame Type

1. Determine the maximum vertical opening dimension between pairs of beams or between the lowest beam level and the floor.
2. Calculate the total load imposed on the upright frame.
3. Using the charts below, find the maximum vertical spacing between beams along the bottom scale, and then draw a vertical line to intersect the lines representing the capacities of the five types of upright frames. Select the frame that has a capacity that equals or exceeds the total load imposed upon it by all beam levels.



Upright Frame Types

Frame Types	Post Width	Post Depth	Post Gauge
F	3"	1-3/4"	14
G	3"	2-1/4"	14
P	3"	3"	14
R	3"	3"	13
T	3"	3"	12

Upright Frame Capacity

Frame Type	Beam Spacing											
	24"	30"	36"	42"	48"	54"	60"	66"	72"	78"	84"	90"
F	22,555	21,213	19,853	18,528	16,929	15,381	13,543	11,773	9,824	8,439	7,216	6,336
G	26,512	25,236	23,839	22,311	20,663	18,904	17,025	15,015	12,864	10,774	9,306	8,110
P	32,751	31,227	29,555	27,932	25,965	24,342	21,871	19,203	17,212	14,630	12,540	11,026
R	39,108	37,264	35,464	33,266	30,891	28,339	25,934	23,043	19,959	17,245	14,796	12,834
T	45,629	43,478	41,102	38,503	35,715	32,703	29,897	26,489	22,875	19,432	16,713	14,527

The table above indicates capacities for various vertical beam spacings for the different Penco upright frame types. Load data shown is for preliminary consideration only. Each installation must be individually evaluated for actual conditions and the use of each element in relation to the entire system with all aspects of the structural function.

Upright Frame Accessories

Rigid Row Spacer

Structurally connects and spaces two rows of rack back-to-back. Bolted type. Hardware included.



Rigid Row Spacer	
Space	Cat. No.
6"	5AR506
8"	5AR508
10"	5AR510
12"	5AR512
18"	5AR518
24"	5AR524
30"	5AR530
36"	5AR536
42"	5AR542
48"	5AR548
54"	5AR554
60"	5AR560

Rigid Wall Spacer

Assures that uniform spacing between pallet rack and building wall is maintained. Frame hardware included.



Rigid Wall Spacer	
Space	Cat. No.
4"	5AR404
6"	5AR406
8"	5AR408
10"	5AR410
12"	5AR412
18"	5AR418

Reel Holder

Accessorizes rack for reel storage. Max. axle 2-1/2" dia. Cat. No. 5AH000



Concrete Floor Anchor

To anchor pallet rack upright frames to a concrete floor. 1/2" diameter x 3-3/4". High seismic areas may require other floor anchors. Check with local permitting agency for assistance, if required. Cat. No. 9580



Frame Protector

Anchors to floor at front of post. Provides protection against damage from material handling vehicles. NOT for use on Pallet Rack PLUS upright frames. Includes hardware to fasten to post only. 18" high. Cat. No. 5AF018



Frame Deflector

Fastens to post only, usually 1-1/2" above the footplate. Includes hardware to bolt to post. 18" High. Cat. No. 5AF021PC



Frame Splice

For adding to height of existing frame. Can be supplied welded in top of new frame if specified on order. (Top frame must be ordered without foot plate.) With hardware.



Frame Splice	
Frame Type	Cat. No.
F, G, P	5AU008P
R, T	5AU018P

Upright Frames - Available Sizes						
Frame Height	Frame Depths					
	30"	36"	42"	48"	54"	60"
48"	I	I	I	I	I	I
54"	I	I	I	I	I	I
60"	I	I	I	I	I	I
66"	I	I	I	I	I	I
72"	I	I	I	I	I	I
78"	I	I	I	I	I	I
84"	I	I	I	I	I	I
90"	I	I	I	I	I	I
96"	I	I	I	I	I	I
102"	I	I	I	I	I	I
108"	I	I	I	I	I	I
114"	I	I	I	I	I	I
120"	I	I	I	I	I	I
126"	I	I	I	I	I	I
132"	I	I	I	I	I	I
138"	I	I	I	I	I	I
144"	I	I	I	I	I	I
150"	I	I	I	I	I	I
156"	I	I	I	I	I	I
162"	I	I	I	I	I	I
168"	I	I	I	I	I	I
174"	I	I	I	I	I	I
180"	I	I	I	I	I	I
186"	I	I	I	I	I	I
192"	I	I	I	I	I	I
198"	I	I	I	I	I	I
204"	I	I	I	I	I	I
210"	I	I	I	I	I	I
216"	I	I	I	I	I	I
222"	I	I	I	I	I	q
228"	I	I	I	I	I	q
234"	I	I	I	I	I	q
240"	I	I	I	I	I	q

I = Available q = Not Available

To add height to an Upright Frame, a splice can be added. For more information on splicing frames see the Frame Splice to the left.

Upright Frame Catalog # System					
Position	1	2	3	4	5
Cat. No.	5	F	E	0	9 6 C

DESCRIPTION OF PART NO. SEQUENCE:

1. Always a 5 2. Capacity code for frame (See Pallet Rack Frame Capacities Table). 3. Depth code for frame (B = 30", E = 36", H = 42", L = 48", P = 54", S = 60") 4. Height of upright frame in inches (for example, 096 = 96 inches). 5. Always ends in "C"

Pallet Rack Beams

One Piece Beam Design

Penco has engineered its roll-formed one piece beams to achieve the highest possible strength-to-weight ratios in the most frequently desired load ratings through the use of efficient design and high strength steel.

Beams are offered in eight basic styles with different vertical profiles and steel gauges. Beam step heights of 7/8" and 1-5/8" are available for a wide variety of accessory use. Both the overlapping seam and the beam end connector are securely MIG welded for strength.

The face of the beam has an M-design recessed configuration for added strength, protecting the locking key, and to accept pressure sensitive labeling. Each beam is stamped with an identifying letter referring to the load bearing capacity. Beams are shown in 710 Yellow.

How to Order Beams

- Select the Required Clear Span (distance between posts).** Allow for a minimum of 3" between pallet and post, and a minimum of 4" between adjacent pallets. Allow additional separation if load overhangs the pallet. For sizes not shown, contact your Penco representative.
- Determine the Required Capacity.** Add up the maximum load to be placed on one pair of beams. Remember that capacities are based on evenly distributed loading, not point loading.

Beam Selection

Clear Span*	B		D		H		J		N		S		X		Y	
	Capacity Per Pair**	Cat. No. Per Pair	Capacity Per Pair**	Cat. No. Per Pair	Capacity Per Pair**	Cat. No. Per Pair	Capacity Per Pair**	Cat. No. Per Pair	Capacity Per Pair**	Cat. No. Per Pair	Capacity Per Pair**	Cat. No. Per Pair	Capacity Per Pair**	Cat. No. Per Pair	Capacity Per Pair**	Cat. No. Per Pair
48"	8920 lb	5BB048	8380 lb	5BD048	9340 lb	5BH048	10670 lb	5BJ048	12170 lb	5BN048	-	-	-	-	-	-
54"	7920 lb	5BB054	7445 lb	5BD054	8370 lb	5BH054	9480 lb	5BJ054	10810 lb	5BN054	-	-	-	-	-	-
60"	7120 lb	5BB060	6695 lb	5BD060	7530 lb	5BH060	8520 lb	5BJ060	9730 lb	5BN060	-	-	-	-	-	-
66"	6470 lb	5BB066	6080 lb	5BD066	6840 lb	5BH066	7740 lb	5BJ066	8830 lb	5BN066	-	-	-	-	-	-
72"	5920 lb	5BB072	5570 lb	5BD072	6260 lb	5BH072	7090 lb	5BJ072	8090 lb	5BN072	9560 lb	5BS072	-	-	-	-
78"	5460 lb	5BB078	5135 lb	5BD078	5770 lb	5BH078	6540 lb	5BJ078	7460 lb	5BN078	-	-	10220 lb	5BX078	-	-
84"	5070 lb	5BB084	4760 lb	5BD084	5360 lb	5BH084	6060 lb	5BJ084	6920 lb	5BN084	-	-	9480 lb	5BX084	12650 lb	5BY084
90"	4720 lb	5BB090	4430 lb	5BD090	4990 lb	5BH090	5650 lb	5BJ090	6450 lb	5BN090	7630 lb	5BS090	8840 lb	5BX090	11800 lb	5BY090
96"	4420 lb	5BB096	3990 lb	5BD096	4670 lb	5BH096	5290 lb	5BJ096	6040 lb	5BN096	7190 lb	5BS096	8280 lb	5BX096	11050 lb	5BY096
102"	4160 lb	5BB102	3530 lb	5BD102	4390 lb	5BH102	4980 lb	5BJ102	5680 lb	5BN102	6720 lb	5BS102	7790 lb	5BX102	10390 lb	5BY102
108"	3920 lb	5BB108	3150 lb	5BD108	3990 lb	5BH108	4690 lb	5BJ108	5340 lb	5BN108	6340 lb	5BS108	7350 lb	5BX108	9800 lb	5BY108
114"	3540 lb	5BB114	2830 lb	5BD114	-	-	4440 lb	5BJ114	-	-	-	-	6950 lb	5BX114	9280 lb	5BY114
120"	3190 lb	5BB120	2550 lb	5BD120	3230 lb	5BH120	4130 lb	5BJ120	4810 lb	5BN120	5690 lb	5BS120	6600 lb	5BX120	8800 lb	5BY120
126"	2900 lb	5BB126	2310 lb	5BD126	-	-	-	-	4570 lb	5BN126	5410 lb	5BS126	6270 lb	5BX126	8370 lb	5BY126
132"	2840 lb	5BB132	-	-	-	-	-	-	4410 lb	5BN132	5160 lb	5BS132	5980 lb	5BX132	7980 lb	5BY132
138"	2410 lb	5BB138	-	-	-	-	-	-	4030 lb	5BN138	-	-	5710 lb	5BX138	7620 lb	5BX138
144"	2220 lb	5BB144	-	-	2240 lb	5BH144	-	-	-	-	4740 lb	5BS144	5500 lb	5BX144	7340 lb	5BY144

NOTE: Beam Capacity is reduced if loading is on the step only, unless beams are stabilized by some form of front to back tie.

* Clear span is measured from inside frame to inside frame.

** Capacity of beam pairs in pounds is calculated in compliance with RMI Specifications and AISI Standard. Calculations assume uniform load distribution. Beams of 138" and 144" span require a minimum of two (2) Heavy Duty Cross Bars.

Beam Accessories

Cross Bars 7/8" Step Beams

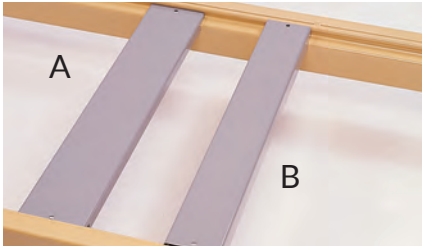

A - 1/2" Plywood Support

Supports sheets of 1/2" Plywood.

A - 1/2" Plywood Support

Frame Depth	Cat. No.
30"	5AP230C
36"	5AP236C
42"	5AP242C
48"	5AP248C

B - General Duty Cross Bar

For supporting loads smaller than unit depth.

B - General Duty Cross Bar

Frame Depth	Cat. No.
30"	5AX530C
36"	5AX536C
42"	5AX542C
48"	5AX548C
54"	5AX554C
60"	5AX560C



Coil Bed

Full depth. For proper placement and storage of cylindrical items.

Coil Bed

Frame Depth	Cat. No.
30"	5AC030C
36"	5AC036C
42"	5AC042C
48"	5AC048C

Cross Bars 1-5/8" Step Beams

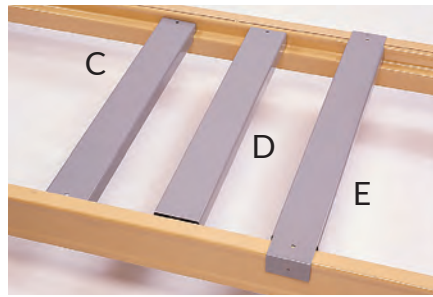

C - 3/4" Plywood Support

Supports sheets of 3/4" Plywood.

C - 3/4" Plywood Support

Frame Depth	Cat. No.
30"	5AP330
36"	5AP336
42"	5AP342
48"	5AP348
54"	5AP354
60"	5AP360

D - General Duty Cross Bar

Supports loads smaller than unit depth on 1-5/8" step beams. Not for plywood.

D - General Duty Cross Bar

Frame Depth	Cat. No.
30"	5AX630C
36"	5AX636C
42"	5AX642C
48"	5AX648C
54"	5AX654C
60"	5AX660C

E - Heavy Duty Flanged Cross Bar

Supports heavier loads smaller than unit depth on 1-5/8" step beams.

E - HD Flanged Cross Bar

Frame Depth	Cat. No.
30"	5AX730C
36"	5AX736C
42"	5AX742C
48"	5AX748C
54"	5AX754C
60"	5AX760C

Fork Clearance Bar and Heavy Duty Skid Channel

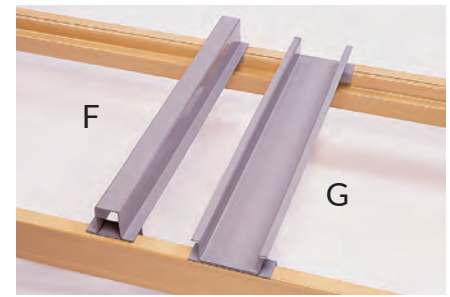

F - Fork Clearance Bar

Provides proper fork clearance for unpalette-ized stock, 2" wide by 2-3/4" high.

F - Fork Clearance Bar

Frame Depth	Cat. No.
30"	5AF330C
36"	5AF336C
42"	5AF342C
48"	5AF348C
54"	5AF354C
60"	5AF360C

G - Heavy Duty Skid Channel Assembly

Provides a channeled base for skid runners, 4" wide by 2" high.

G - HD Skid Channel Assembly

Frame Depth	Cat. No.
30"	5AS230C
36"	5AS236C
42"	5AS242C
48"	5AS248C

H - Pallet Stop

Attaches to rear beam with Tek screw. Cat. No. 08822 included. For 1-5/8" step beam only. In Pairs. Cat. No. 5AT00H

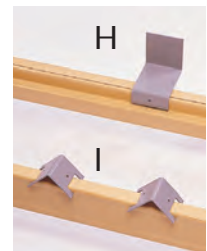

I - Drum Wedge

Two loose triangular stops for drum storage. Install on front beam only. In Pairs. Cat. No. 5AW000

PALLET RACK: The basic components of Standard Penco Pallet Rack are Upright Frames and Beams. Each is manufactured to exacting tolerances to provide many years of dependable service at their rated loads.

Step Down Design: All beams have a step for the purpose of accepting accessories. Two step sizes are available: 7/8" and 1-5/8" high.

Beam Locking Key For Safety: A unique recessed safety key made from heavy gauge steel engages a slot in the side of the post. As soon as beams are installed, the locking keys should be slid into place. They will resist an upward force from material handling equipment up to 1000 pounds. It is an integral part of the beam assembly, can be engaged easily without tools, and is clearly visible for checking.

Heavy Duty Beam End Connector: Beam ends are made from extra heavy gauge steel. They feature a three prong connection which assures positive beam to post alignment along the 8-1/2" length of the connector, and uniform load distribution. Tabs extend along the face of the beam to provide extra protection to the prongs during transit and installation.

Heavy Duty Beam End Connector (Pallet Rack Plus): Pallet Rack Plus beams are intended for use in severe conditions or high seismic areas and have four pronged end frame connectors. The beams are centered along the 11 1/2" long connector so all prongs share equally in the live beam load. Any Penco pallet rack beam can be equipped with four-pronged connectors.

Welded Upright Frame Bracing: Upright frame columns are securely MIG welded together with channel type braces for maximum rigidity.

Upright Column: A continuous post roll formed into an "M" design for added strength. Slanted slots on the column allow for beam placement on 3" vertical centers. The greater the unit load the tighter the beam-upright connection becomes. Slots on column sides accept the safety beam locking key. The design allows for standard beams to be placed flush with the top, or as close as 9" from the floor.

Upright Column (Pallet Rack Plus): A continuous post roll formed into an "M" design for added strength. Slanted slots on the column allow for beam placement on 3" vertical centers. The greater the unit load the tighter the beam-upright connection becomes. All Plus pallet rack beams are attached 3" down from the top of the heavy duty connector and cannot be installed flush with the top of the uprights. Plus beams can be placed within 9" above the floor.

Foot Plate: A heavy gauge foot plate is securely welded to each post to provide load distribution over 13.7 square inches, and two 9/16" holes allow for floor anchoring on either side of the frame. Standard duty foot-plates are 7 ga. thick.

Foot Plate (Pallet Rack Plus): All pallet rack Plus upright frames have foot-plates that are 35 square inches and 3/8" thick. Four 9/16" holes are present at the corners for anchoring.

Pallet Rack Frames: Penco Pallet Rack Upright Frames are available in five different load carrying ranges. A letter code stamped into the face of the post indicates the frame type. Depths of 30", 36", 42", 48", 54" and 60" are standard, but other depths are available. Standard heights range from 48" to 240" in 6" increments, but greater heights can be achieved when splices are used. Double posted and cantilever leg custom upright configurations are available upon request. Beam heights adjust on 3" vertical centers, and are independent on each side of the frame. Various load rated frames can be combined in a row of rack for maximum economy. Beams cannot be placed at locations where a splice is positioned. Penco Pallet Rack Upright

Frames are furnished completely fabricated, welded into rigid units. Standard finish for upright frames is 028 Gray baked enamel. Other standard Penco colors are available upon request.

We recommend that all upright frames be securely anchored to the floor for safety. Seismic conditions and local codes may require anchors other than the Penco 1/2"-13 x 3 3/4" wedge anchor be used. We suggest you check with local code officials about anchoring as many jurisdictions have approved different anchors.

Pallet Rack Beams: Penco has engineered its roll-formed one piece beam to achieve the highest possible strength-to-weight ratios in the most frequently desired load ratings through the use of efficient design and high strength steel. Beams are offered in eight basic styles with different vertical profiles and steel gauges. Beam step heights of 7/8" and 1-5/8" are available for a wide variety of accessory use. Both the overlapping seam and the beam end connector are securely MIG welded for strength. The face of the beam has an M-design recessed configuration for added strength, protecting the locking key, and to accept pressure sensitive labeling. Each beam is stamped with an identifying letter referring to the load bearing capacity. Beams are finished in 710 Sagebrush Yellow baked enamel for high visibility. Safety Yellow and any other standard Penco colors are available upon request.

PALLET RACK ACCESSORIES

Plywood Supports: For supporting plywood or other wood decking. Styles are available for 1/2" deck on 7/8" step beams and 3/4" deck on 1-5/8" step beams.

General Duty Cross Bars: For supporting loads smaller than unit depth.

Heavy Duty Flanged Cross Bar: Supports heavier loads smaller than unit depth on 1-5/8" step beams.

Fork Clearance Bar: Provides proper fork clearance for unpalletized stock, 2" wide by 2-3/4" high.

Heavy Duty Skid Channel Assembly: Provides a channeled base for skid runners, 4" wide by 2" high.

Frame Splice: For adding to height of existing frame. Can be supplied welded in top of new frame if specified on order. (Top frame must be ordered without foot plate.) Hardware provided.

Frame Protector: Anchors to floor at front of post. Provides protection against damage from material handling equipment.

Frame Deflector: Fastens to front of upright post on 3" increments.

Rigid Wall Bracket: Structurally connects racks to wall for additional stability. Frame hardware included.

Rigid Row Spacer: Structurally connects and spaces two rows of rack back-to-back to satisfy NFPA requirements. Bolted into place. Hardware included.

Reel Holder: Accessorizes rack for elevated reel storage. Capacity is 1,000 lbs./pair and they can hold axels up to 2 1/2" diameter. Hardware included.

Decking: Decking for Pallet Rack is available in a number of formats that include wire, steel and wood.

PENCO RESERVES THE RIGHT TO VARY SPECIFICATIONS CONSISTENT WITH A POLICY OF CONTINUOUS PRODUCT IMPROVEMENT.

Pallet Rack Plus Specifications

PALLET RACK PLUS: The basic components of Penco Pallet Rack Plus are Upright Frames and Beams. Each is manufactured to exacting tolerances to provide many years of dependable service at their rated loads. Other components and accessories are available

Step Down Design: All beams have a step for the purpose of accepting accessories. Two step sizes are available: 7/8" and 1-5/8" high.

Beam Locking Key for Safety: A unique recessed safety key installed into each beam connector that is made from heavy gauge steel engages a slot in the side of the post. As soon as beams are installed, the locking key should be slid into place. They will resist an upward force from material handling equipment up to 1000 pounds. It is an integral part of the beam assembly, can be engaged easily without tools, and is clearly visible for checking.

Heavy Duty Beam End Connector: Pallet Rack Plus beams are intended for use in severe conditions or high seismic areas and have four pronged end frame connectors. The beams are centered along the 11 1/2" long connector so all prongs share equally in the live beam load. Any Penco pallet rack beam can be equipped with four-pronged connectors.

Welded Upright Frame Bracing: Upright frame columns are securely MIG welded together with channel type braces for maximum rigidity.

Upright Column: A continuous post roll formed into an "M" design for added strength. Slanted slots on the column allow for beam placement on 3" vertical centers. The greater the unit load the tighter the beam-upright connection becomes. All Plus pallet rack beams are attached 3" down from the top of the heavy duty connector and cannot be installed flush with the top of the uprights. Plus beams can be placed within 9" above the floor.

Foot Plate: All pallet rack Plus upright frames have footplates that are 35 square inches and 3/8" thick. Four 9/16" holes are present at the corners for anchoring.

PALLET RACK FRAMES: Penco Pallet Rack Plus Upright Frames are available in five different load carrying ranges. A letter code stamped into the face of the post indicates the frame type. Depths of 30", 36", 42", 48", 54" and 60" are standard, but other depths are available. Standard heights range from 48" to 240" in 6" increments, but greater heights can be achieved when upright frames are spliced together. Double posted and Cantilever leg custom upright configurations are available upon request. Beam heights adjust on 3" vertical centers, and are independent on each side of the frame. Various load rated frames can be combined in a row of rack for maximum economy. Beams cannot be placed at locations where a splice is positioned. Penco Pallet Rack Upright Frames are furnished completely fabricated, welded into rigid units. Standard finish for upright frames is 028 Gray baked powdercoat enamel. Other standard Penco colors are available upon request. We recommend that all upright frames be securely anchored to the floor. Seismic conditions and local codes may require anchors other than the Penco 1/2"-13 x 3 3/4" wedge anchor be used. We suggest you check with local code officials about anchoring as many jurisdictions have approved different anchors.

PALLET RACK BEAMS: Penco has engineered its roll-formed one piece beam to achieve the highest possible strength-to-weight ratios in the most frequently desired load ratings through the use of efficient design and high strength steel. Beams are offered in eight basic styles with different vertical profiles and steel gauges. Beam step heights of 7/8" and 1-5/8" are available for a wide variety of accessory use. Both the overlapping seam and the beam end connector are securely MIG welded for strength. The face of the beam has an M-design recessed configuration for added strength, protecting the locking key, and to accept pressure sensitive labeling. Each beam is stamped with an identifying letter referring to the load bearing capacity. Beams are finished in 710 Sagebrush Yellow baked enamel for high visibility. Safety Yellow and any other standard Penco colors are available upon request.

PALLET RACK ACCESSORIES

Plywood Supports: For supporting plywood or other wood decking. Styles are available for 1/2" deck on 7/8" step beams and 3/4" deck on 1-5/8" step beams.

General Duty Cross Bars: For supporting loads smaller than unit depth.

Heavy Duty Flanged Cross Bars: Supports heavier loads smaller than upright end frame depth. Only available for use with 1-5/8" step beams.

Fork Clearance Bar: Provides proper fork clearance for loads not on pallets. Fork clearance bars are 2" wide by 2-3/4" high.

Heavy Duty Skid Channel Assembly: Provides a channeled base for skid runners, 4" wide by 2" high.

Frame Splice: For adding to height of existing frame. Can be supplied welded in top of new frame if specified on order. (Top frame must be ordered without foot plate.) With hardware. Can be used with standard or Plus uprights. Length of splice allows for two bolt locations on each side of the splice joint. Hardware for attachment is included. Top frames must be ordered without footplates.

Frame Protector: Anchors to floor at front of post. Provides protection against damage from material handling vehicles.

Frame Deflector: Fastens to front upright post on 3" increments.

Rigid Wall Bracket: Structurally connects racks to wall for additional stability. Frame hardware included.

Rigid Row Spacer: Structurally connects and spaces two rows of rack back-to-back to satisfy NFPA requirements. Bolted type. Hardware included.

Reel Holder: Accessorizes pallet rack for elevated reel storage. Capacity is 1,000 lbs/pair and they can hold axles up to 2 1/2" diameter. Hardware is included.

Decking: Decking for pallet rack is available in a number of formats that include wire, steel and wood.