

8 7 6 5 4 3 2 1

REVISIONS			
REV.	DESCRIPTION	DATE	APPROVED
A	REVISION #20-2456	10/1/2020	TM

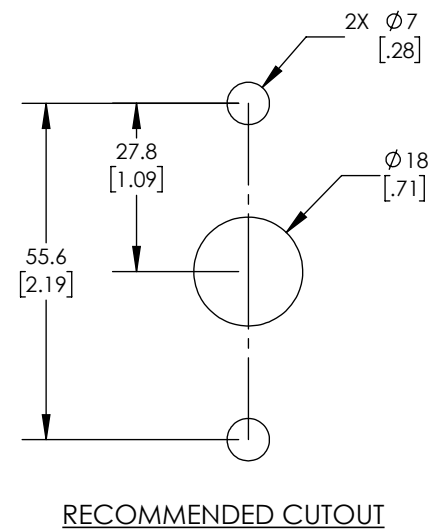

ITEM NO.	PART NUMBER	DESCRIPTION	QTY.
1	2554-FCR	RFID KEY PAD, RIGHT HINGE	1
2	5200-302	5200 SLAM BOLT ASSEMBLY	1
3	5200-03	#10-32 MOUNTING NUTS: ZINC PLATED STEEL	2

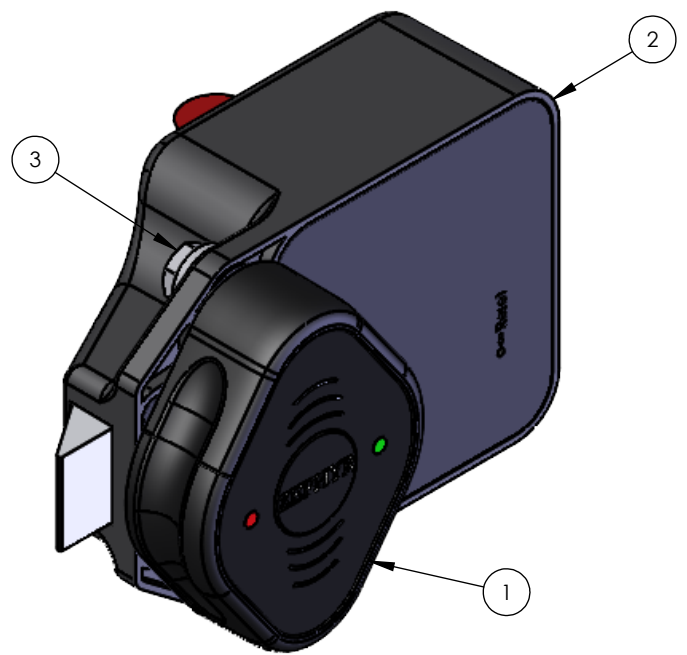
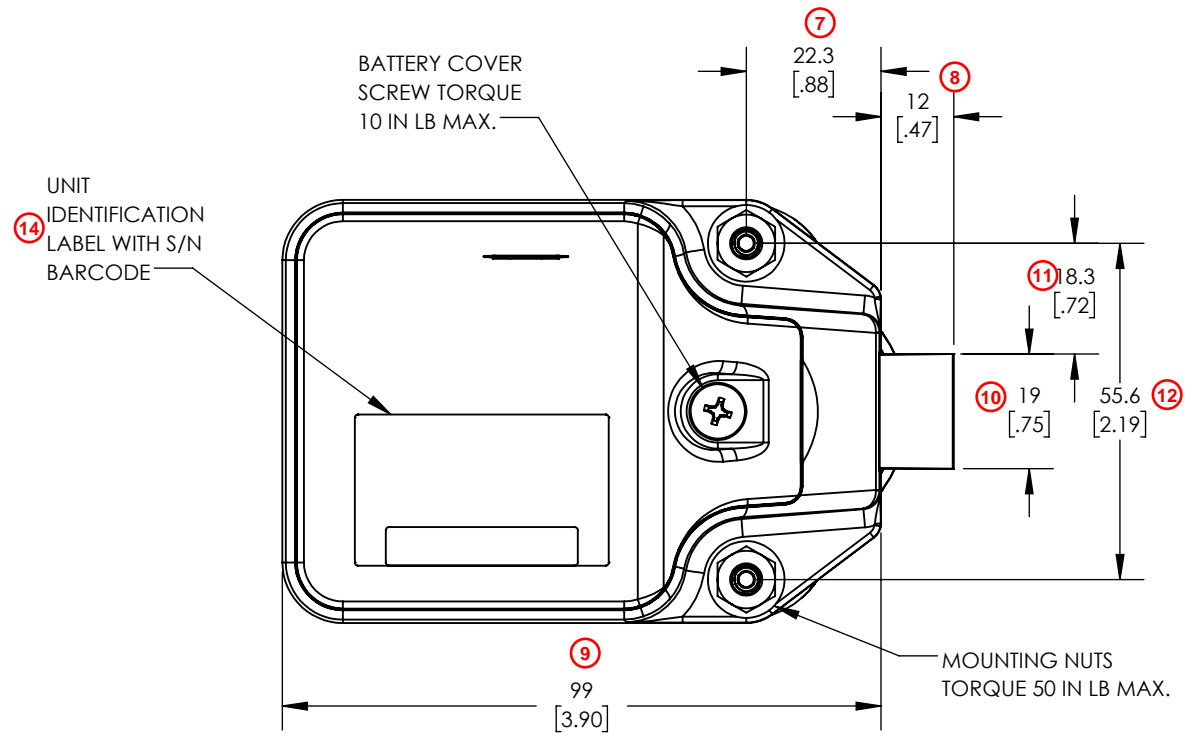
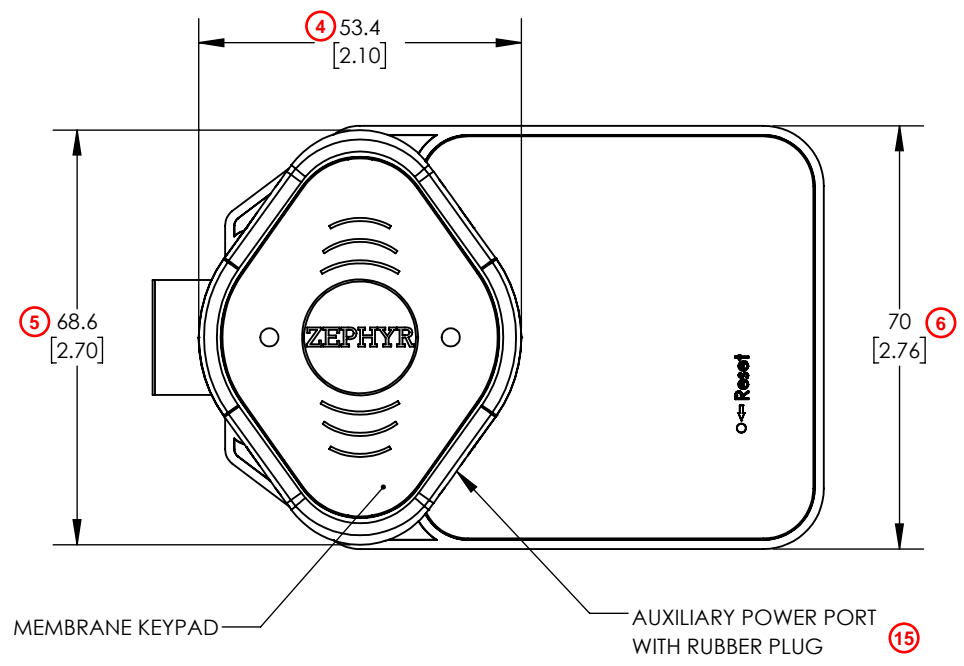
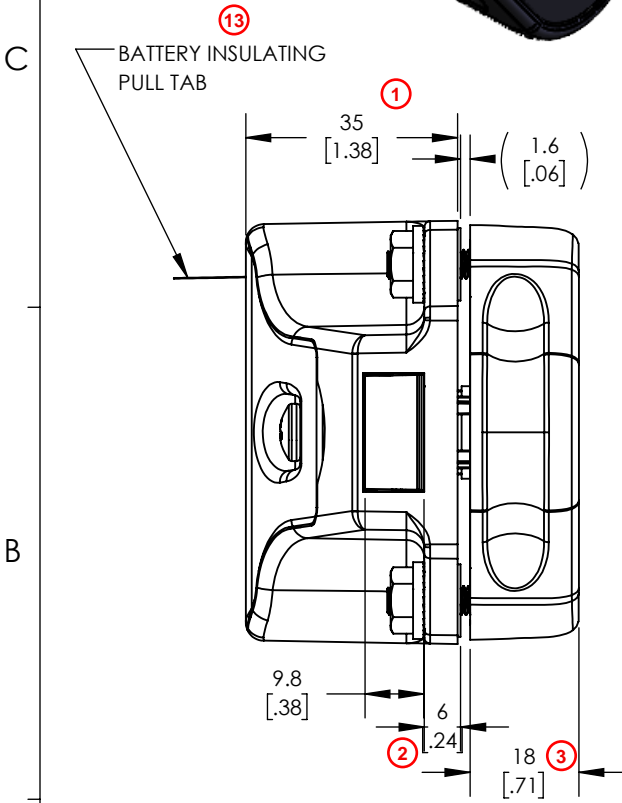

- NOTES:
- UNMARKED FEATURES CONTROLLED BY 3D MODELS.
  - FINISHES:
    - LOCK HOUSING: BLACK
    - KEYPAD MEMBRANE: BLACK, ANTIMICROBIAL - ISO 22196
    - NUMBERS AND SYMBOLS: WHITE, ALCOHOL RESISTANT
    - FCR: ANTIMICROBIAL - ISO 22196
  - INSPECT PER "5200\_QCP".

**PROPRIETARY INFORMATION**  
 DATA CONTAINED WITHIN BELONGS TO WIND HARDWARE & ENGINEERING, WINDMADE PRODUCTS, ZEPHYR LOCKS AND/OR ZEPHYR FLUID SOLUTIONS AND SHALL NOT BE DISTRIBUTED OUTSIDE THE RECIPIENT'S FACILITY AND SHALL NOT BE DUPLICATED, USED, OR DISCLOSED IN WHOLE OR IN PART FOR ANY PURPOSE OTHER THAN EVALUATION OR MAINTENANCE OF THIS MATERIAL. NO RIGHT IS GRANTED FOR THE MANUFACTURING IN WHOLE OR IN PART OF ANY ITEMS ON THIS DRAWING WITHOUT THE WRITTEN CONSENT FROM ONE OF THE ENTITIES LISTED.

UNLESS OTHERWISE SPECIFIED:  
 DIMENSIONS ARE IN METRIC  
 TOLERANCES:  
 ANGULAR: MACH ±1° BEND ±1°  
 ONE PLACE DECIMAL ±0.25  
 TWO PLACE DECIMAL ±0.13

MATERIAL  
 SEE PARTS

FINISH  
 SEE NOTES

NAME	DATE
DRAWN NPI	5/12/2020
CHKR	
ENGR	
QUAL	
	PJ12221
NEXT ASSY	USED ON
<b>REGULATORY COMPLIANCE</b>	
ALL PARTS MUST COMPLY WITH THE LATEST REACH AND ROHS STANDARDS.	

**ELECTRONIC RFID & KEYPAD LOCK, RFID ONLY, CUSTOMER SPECIFIC, RIGHT HINGE**

**WIND Hardware / ZEPHYR Lock**

SIZE	FSCM NO.	DWG. NO.	REV
<b>B</b>	-	<b>2554</b>	<b>A</b>

SCALE: 1:1.25    WEIGHT: 186.78    SHEET 1 OF 20

10/1/2020  
2600

8 7 6 5 4 3 2 1